

HART Block

User Manual



ABUS TECHNOLOGIES INC.

WARNING

- ❖ This manual should be passed on to the end user.
- ❖ The contents of this manual are subject to change without prior notice.
- ❖ All rights reserved.
- ❖ ABUS gives no warranty of any kind with regard to this manual, including, but not limited to, fitness for a particular purpose.
- ❖ If any question arises or errors are found, or if any information is missing from this manual, please inform your supplier or inform at info@abustek.com.
- ❖ The specifications mentioned in this manual are limited to those for the standard type under the specified model number break-down and do not necessarily apply for customized instruments.
- ❖ Please note that changes in the specifications, construction, or component parts of the instrument may not immediately be reflected in this manual at the time of change.
- ❖ If the customer or any third party is harmed by the use of this product, ABUS assumes no responsibility for any such harm owing to any defects in the product which were not predictable, or for any indirect damages.
- ❖ The integral modules specifically HART module are not manufactured by ABUS.

Although Warning hazards are related to personal injury, and Caution hazards are associated with equipment or property damage, it must be understood that operation of damaged equipment could, under certain operational conditions, result in degraded process system performance leading to personal injury or death. Therefore, comply fully with all Warning and Caution notices.

Information in this manual is intended only to assist our customers in the efficient operation of our equipment. Use of this manual for any other purpose is specifically prohibited and its contents are not to be reproduced in full or part without prior approval of Technical Communications Department, ABUS Technologies

HEALTH AND SAFETY

To ensure that our products are safe and without risk to health, the following points must be noted:

1. The relevant sections of these instructions must be read carefully before proceeding.
2. Warning labels on containers and packages must be observed.
3. Installation, operation, maintenance and servicing must only be carried out by suitably trained personnel and in accordance with the information given. Any deviation from these instructions will transfer the complete liability to the user.
4. Normal safety precautions must be taken to avoid the possibility of an accident occurring when operating in conditions of high pressure and/or temperature.
5. Chemicals must be stored away from heat, protected from temperature extremes and powders kept dry. Normal safe handling procedures must be used.
6. When disposing of chemicals ensure that no two chemicals are mixed.

Safety advice concerning the use of the equipment described in this manual or any relevant hazard data sheets (where applicable) may be obtained from the Company address on the back cover, together with servicing and spares information.

CATALOGUE

Contents	Page No.
1. Introduction	4
2. Presentation	4
1. Features	4
2. Technical Parameters	4
3. Dimensions	5
4. Connections	6
5. Installation	6
Input Signal	6
6. Configuration	7
1. USB Interface	7
2. HART Modem	7
7. Safety Precautions	8
8. Warranty	8

1. INTRODUCTION

HART Block is a Smart and universal 2-wire In-head transmitter for temperature and other measurement applications. HART Block is the Intrinsic Safe version for use in Ex-applications. HART Block is fully HART-compatible, with communication through the HART protocol, directly on the 4-20 mA output loop, by using general hand-held HART Communicator, which facilitates the access to and use of functions like transmitter configuration, documentation, monitoring and calibration.

2. PRESENTATION

2.1 Features

1. Universal settings with HART-protocol for various input signals.
2. 2 wire technology, 4 to 20mA analogue output
3. High accuracy in total ambient temperature range
4. Galvanic isolation
5. An internal temperature sensor for active temperature compensation(For T/C)
6. Wide voltage supply range
7. Expanded resistance input (max 10K)
8. Expanded voltage input (max 2KmV)

2.2 Technical Parameters

OUTPUT

<i>Output signal:</i>	4 ~ 20 mA
<i>Signal on alarm:</i>	Under ranging Linear drop to 3.8 mA. Over ranging Linear rise to 20.8 mA. Sensor Break; Sensor open-circuit 3.8 mA.
<i>Load:</i>	max.(V _{Power Supply} -7.5 V)/0.0208 A
<i>Linearization/Transmission behaviour:</i>	Temperature linear, resistance linear, voltage linear.
<i>Galvanic isolation:</i>	U=2 KV AC (input/output).

Power Supply (polarity protected): 7.5 ~ 45 VDC (without display).

PERFORMANCE

<i>Response time:</i>	1s
<i>Reference operating conditions:</i>	Calibration temperature 23°C (73.4°F) ±5K
<i>Long term stability:</i>	≤0.05% per year.
<i>Switch on delay:</i>	≤ 5s
<i>Influence of ambient:</i>	Negligible
<i>Load Influence:</i>	Negligible
<i>Power Supply Influence:</i>	Negligible
<i>Self stability configuration:</i>	0 ~ 2%
<i>Filter configuring:</i>	0 ~ 160 μ A
<i>Resolution:</i>	0.3 μ A

ENVIRONMENT CONDITIONS

<i>Ambient temperature:</i>	-40 ~ 85°C (-40°F ~ 185°F)
<i>Storage temperature:</i>	-40 ~ 100°C (-40°F ~ 212°F)
<i>Condensation:</i>	Allowable
<i>Degree of protection:</i>	IP00
<i>Shock and vibration resistance:</i>	4g/2 ~ 150 Hz as per IEC 60 068-26
<i>Electromagnetic compatibility (EMC):</i>	Interference immunity and interference emission according to GB/T17626.2 (1998), compliance with IEC 61 000-4-3 (1995).
<i>Installation Instruction:</i>	Installation angle: no limit.

MATERIALS

<i>Dimensions:</i>	Dia. 44 mm x 22.5 mm
<i>Materials:</i>	Housing: PC, Plotting: epoxy
<i>Weight: Approx.</i>	33.5 g

Maximum measured error

INPUT	TYPE	MEASUREMENT ACCURACY
Resistance thermometer RTD	Pt100, Ni100	0.2 K or 0.08 %
	Pt500, Ni500	0.5 K or 0.20 %
	Pt1000, Ni1000	0.3 K or 0.12 %
	Cu50	0.2 K or 0.08 %
	Cu100	0.3 K or 0.12 %
Thermocouple TC	K, J, T, E	Typ.0.5K or 0.08 %
	N	Typ.1.0K or 0.08 %
	S, B, R	Typ.2.0K or 0.08 %
Resistance transmitter (Ω)	0 to 400 Ω	±0.1 Ω or 0.08 %
	0 to 2000 Ω	±1.5 Ω or 0.12 %
	0 to 10000 Ω	±7.5 Ω or 0.20 %
Voltage Transmitter (mV)	-10 to 75 mV	±20 μ V or 0.08 %
	-100 to 100 mV	±20 μ V or 0.08 %
	-100 to 500 mV	±30 μ V or 0.08 %
	-100 to 2000 mV	±50 μ V or 0.08 %

3. DIMENSIONS

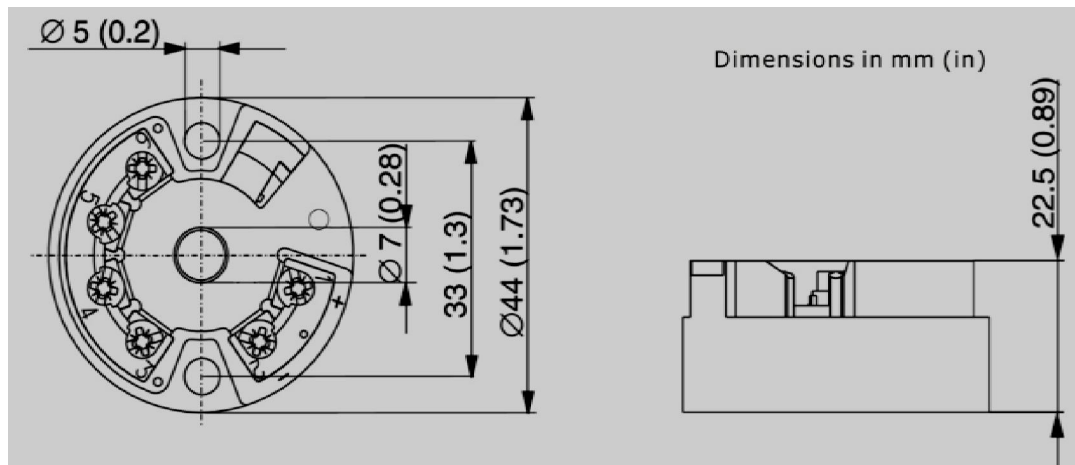

4. CONNECTIONS

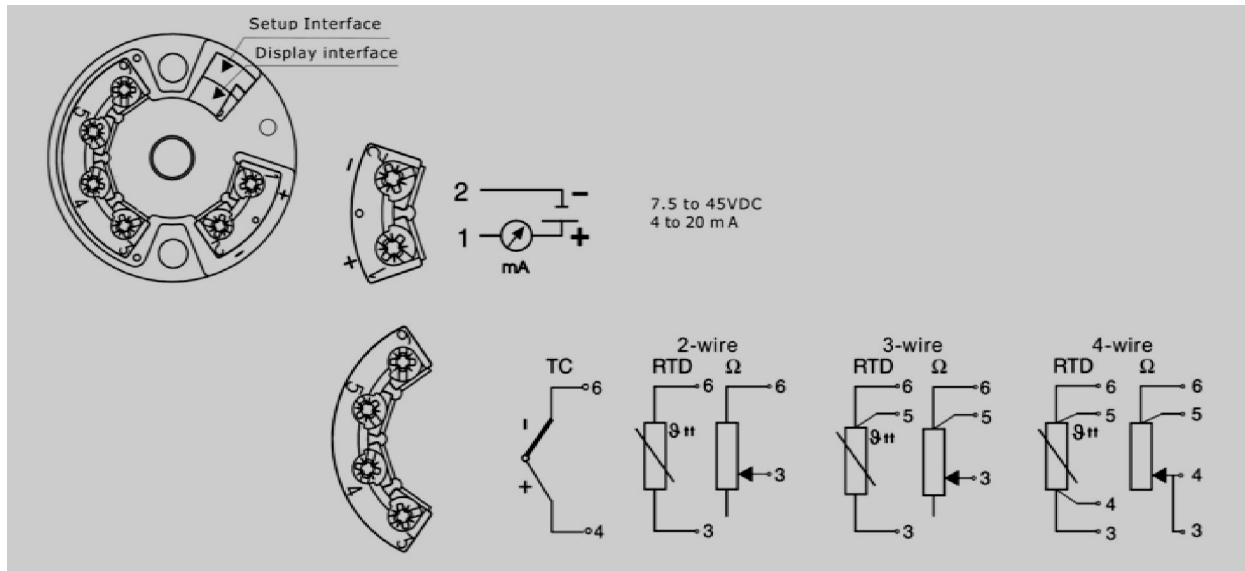

5. INSTALLATION

Input Signal

INPUT SIGNAL	TYPE	MEASUREMENT RANGES	MINIMUM MEASUREMENT RANGES
Resistance Thermometer (RTD)	Pt100	-200°C ~ 850°C (-328°F ~ 1562°F)	10 K
	Pt500	-200°C ~ 250°C (-328°F ~ 482°F)	10 K
	Pt1000	-200°C ~ 250°C (-328°F ~ 482°F)	10 K
	Cu50	-50°C ~ 150°C (-58°F ~ 302°F)	10 K
	Cu100	-50°C ~ 150°C (-58°F ~ 302°F)	10 K
	*Ni100	-60°C ~ 180°C (-76°F ~ 356°F)	10 K
*Ni500	-60°C ~ 180°C (-76°F ~ 356°F)	10 K	
*Ni1000	-60°C ~ 150°C (-76°F ~ 302°F)	10 K	
Resistance Transmitter	Resistance (Ω)	0 ~ 400 Ω 0 ~ 2000 Ω 0 ~ 10000 Ω	10 Ω 20 Ω 100 Ω

*α = 5000 ppm/K or 6180 ppm/K
 Connection type: 2-,3- or 4-wire connection
 Sensor current: 0.5 mA

INPUT SIGNAL	TYPE	MEASUREMENT RANGES	MINIMUM MEASUREMENT RANGES
Thermocouples (TC)	B(PtRh30-PtRh6) E(NiCr-CuNi) J(Fe-CuNi) K(NiCr-Ni) N(NiCrSi-NiSi) R(PtRh13-Pt) S(PtRh10-Pt) T(Cu-CuNi)	0 ~ 1820°C (32 ~ 3308°F) -270 ~ 1000°C (-454 ~ 1832°F) -210 ~ 1200°C (-346 ~ 2192°F) -270 ~ 1372°C (-454 ~ 2501°F) -270 ~ 1300°C (-454 ~ 2372°F) -50 ~ 1768°C (-58 ~ 3214.4°F) -50 ~ 1768°C (-58 ~ 3214.4°F) -270 ~ 400°C (-454 ~ 752°F)	500K 50K 50K 50K 50K 500K 500K 50K
Voltage Transmitters (mV)	Milli-volt transmitter (mV)	-10 ~ 75 mV -100 ~ 100 mV -100 ~ 500 mV -100 ~ 2000 mV	5 mV 5 mV 6 mV 20 mV

6. CONFIGURATION

6.1 USB Interface

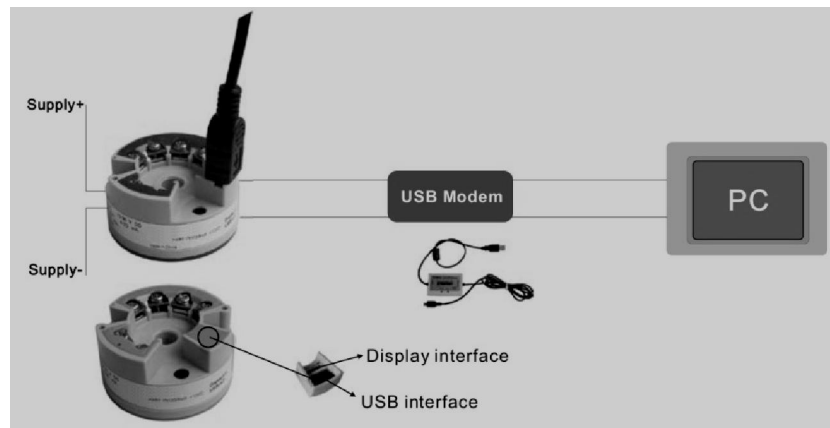

6.2 HART Modem

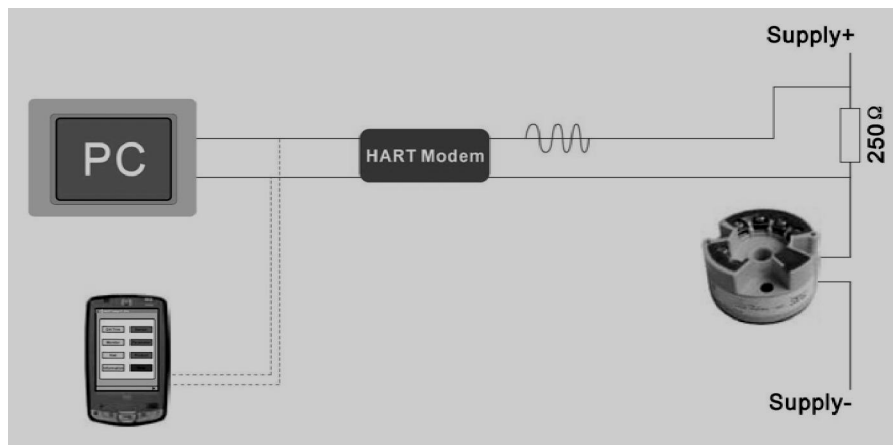

7. SAFETY PRECAUTIONS

1. The unit should be powered for 15 minutes before use.
2. Use in ambient temperature of 0-60°C.
3. Avoid vibrations, shock, excessive dust, corrosive chemical materials or gaseous environment.
4. Input wire should not be too long. If measured signal have to be far away from the unit, please use 2-core shielded cable.
5. Use this instrument in the scope of its specifications, otherwise fire or malfunctions may result.
6. Contact of the instrument, with organic solvents or oils should be avoided.
7. Do not turn on the power supply until all of the wiring is completed. Otherwise electrical shock, fire or malfunction may result.
8. Do not disassemble, repair or modify the instrument.
9. All connections should be tightened properly.
10. Power supply should be constant, should not be fluctuating.

8. WARRANTY

ABUS provides the original purchaser of this instrument a one (1) year warranty against defects in material and workmanship under the following terms:

- The one year warranty begins on the day of shipment as stated on the sales bill.
- During the warranty period all costs of material and labor will be free of charge provided that the instrument does not show any evidence of misuse.
- For maintenance, return the instrument with a copy of the sales bill to our factory.
- All transportation and insurance costs should be covered by the owner of the equipment.
- Should any sign of electrical or mechanical shock, abuse, bad handling or misuse be evident the warranty voids and maintenance costs will be charged.