

8800/889 SERIES

INSTALLATION AND OPERATING INSTRUCTIONS

8800/889 Series - ATEX certified GC Ex nA with Mag-Pac module



SIRA 08 ATEX 4277X
Ex nA IIC T3 Gc

The equipment may be used in a CAT 3 environment in the presence of flammable gases and vapours only.

The apparatus groups cover IIA, IIB and IIC with temperature classes of T1, T2 and T3 with an ambient temperature range -20 to +70°C.

This document details an identical build that can be sold in different locations worldwide. For this reason the product has two series numbers as indicated below:

- Series 8800
- Series 889

The valve control monitor provides three methods of end of travel indication by the means of two sealed bifurcated integral switches and input circuit LED's which are located in the Mag-Pac module and an external visual indicator (if fitted).

The enclosure comprises of a two parts, a cover and housing. This series is available in two enclosure materials, aluminium and 316 stainless steel. The Mag-Pac module is located within the enclosure along with the solenoid coil.

The housing can offer up to two of the following conduit entries; M20 x 1.5p, M25 x 1.5p, ½"-14 NPT or ¾"-14 NPT cable entries for connection to an external power source via appropriate certified cable glands.

Note: before installation of this product, please ensure that the product and its certification is suitable for the intended application. This product uses various O-ring materials and an Eastar Copolyester visual indicator - if fitted.

If the equipment is likely to come into contact with aggressive substances, then it is the responsibility of the user to take suitable precautions that prevent it from being adversely affected, thus ensuring that the type of protection provided by the equipment is not compromised.

The unit has an ingress protection of IP66/67 and therefore any conduit device fitted must maintain this.

Note: these products are not intended to be assembled directly to process pipe work etc that is heated or cooled to temperatures outside of the range as indicated above.

With regards to safety it is not necessary to check for correct operation.

WARNING

Do not open when energized or following site procedures, ensure that the local surroundings is free of explosive atmosphere.

WARNING

Electrostatic hazard, clean only with damp cloth.

WARNING

Ensure that this product is not located in areas, when in use, where propagating brush discharge can occur such as near door ways, fans or fast moving air flow.

The certification is compliant against the following standards

EN 60079-0:2006	Electrical apparatus for explosive gas atmospheres - Part 0 - General requirements
EN 60079-15:2005	Electrical apparatus for explosive gas atmospheres - Construction, test and marking of type of protection 'n' electrical apparatus

1 MOUNTING INSTRUCTIONS

- 1.1 Attach the mounting bracket and adaptor (if required) to the Quantum housing and shaft with the fasteners provided with the mounting kit.
- 1.2 To ensure that the Quantum is mounted correctly, it may be necessary to stroke the actuator to the fully closed position.

WARNING

Before stroking the actuator to either end position, please ensure that the process is safe to do so.

- 1.3 With the actuator in the correct position, attach the Quantum / bracket to the actuator using the hardware provided in the mounting kit.
- 1.4 To release the cover, loosen the cover retaining screws. Twist the cover approx 45° and lift up. See Figure 1.
- 1.5 To set switches, lift the bottom cam and turn until the switch has activated (LED lit) and then release. The spring will push the cam back onto the splined shaft.

WARNING

Before stroking the actuator, please ensure that the process is safe to do so and that all hands are kept away from the moving shaft.

- 1.6 Stroke the actuator to the opposite end of travel. Set the top cam by pushing down and turning the cam until the switch is activated.

WARNING

Before stroking the actuator, please ensure that the process is safe to do so and that all hands are kept away from the moving shaft.

- 1.7 Stroke the actuator from one end of stroke to the other several times to check the switch operation. If the switches require adjustment, repeat steps 1.5 to 1.7. See Figure 2.

FIGURE 1

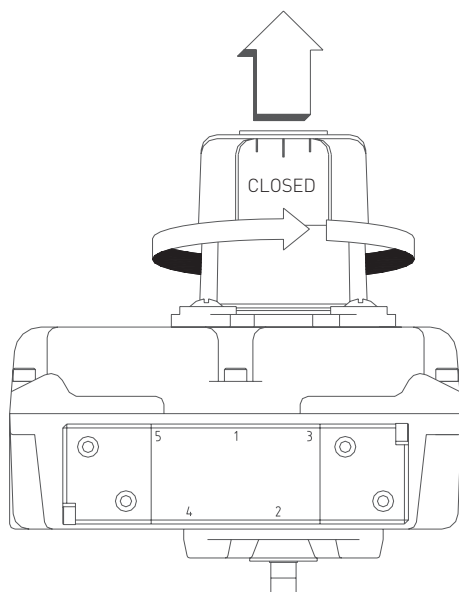
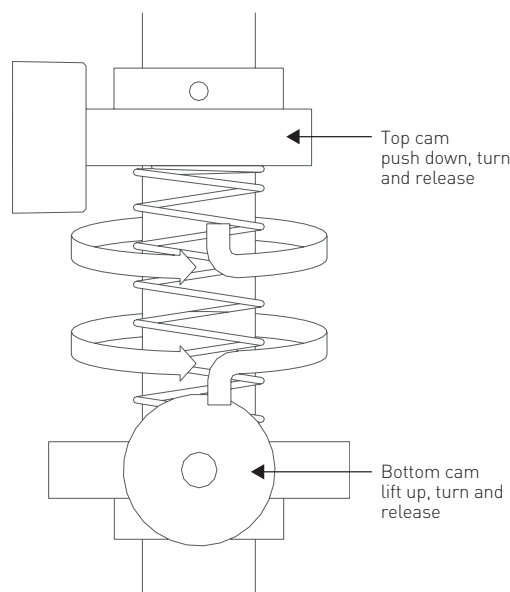

FIGURE 2



8800/889 SERIES

INSTALLATION AND OPERATING INSTRUCTIONS

2 FIELD WIRING AND INSTALLATION

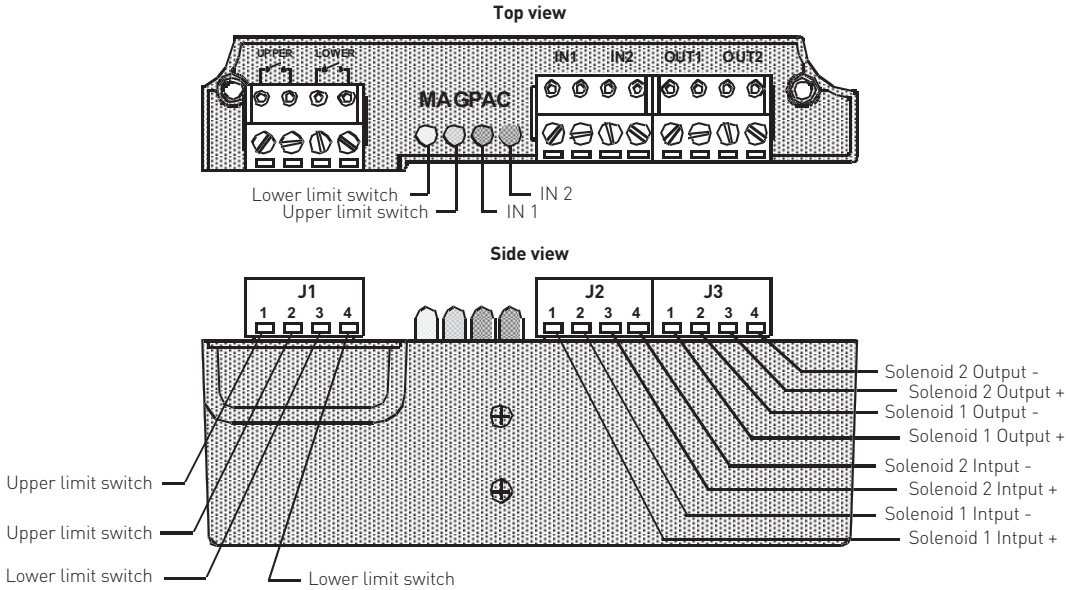

WARNING

Before electrical installation, please read and follow the wiring diagram located inside the cover. The electrical ratings can be found on the product I.D label.

Note: the valve monitors shall be connected to a device which prevents supply voltage transients in excess of 40% occurring at the apparatus power supply.

The Mag-Pac has high reliability hermetically sealed bifurcated switches with LED indication for open and closed limits and indication of which solenoid is being operated.

Contact	(2) Normally open
Rated voltage (J1) (input switches)	12 - 24 VDC (polarity insensitive)
Rated current (J1) (input switches)	
Minimum	2 mA to light LED
Maximum	Max. 500 mA
Voltage drop max.	5 VAC / VDC
Operating time	4 ms or less
Releasing time	2 ms or less
Operating temp	-40°C - +85°C
Coil input voltage (J2 and J3)	24 VDC - 0.5 W

- 2.1 Field wiring must be carried out in accordance with site, local and national electrical codes / requirements. This includes special attention to earth bond to the Aluminium enclosure using the internal and external earth points provided.
- 2.2 Installation of this product shall be carried out by competent personnel in accordance with the applicable code of practice such as EN 60079-14.

ATTENTION

Each Mag-Pac connector screw that has been used must be sealed with an RTV type sealant to maintain reliable screw contact pressure.

8800/889 SERIES

INSTALLATION AND OPERATING INSTRUCTIONS

2.3 The monitor housing can offer up to three of the following conduit entries: M20 x 1.5p, M25 x 1.5p, 1/2"-14 NPT, 3/4"-14 NPT or Pg 13.5. These entries are detailed on the product I.D label found on the product cover. Please see Figure 3 for conduit positions.

2.4 The certification applies to equipment without cable glands. When mounting the enclosure in the hazardous area, only suitably ATEX Ex e certified glands must be used maintaining IP66/67.

2.5 All unused cable entries must be plugged with a suitably rated IP66/67 blanking devices.

2.6 Westlock nomenclature - Series 8800
The first two digits of the nomenclature signifies the series with the third digit defining whether the product has a visual beacon or not. The table below details the applicable ambient ranges:

Series code	Cover type
884*	Beacon
886*	Flat

Westlock nomenclature - Series 889
Available in aluminium and stainless steel. Please contact the sales office for the part number 'P' code suffix number that is applied to the end of the catalog code that details aluminium or stainless steel. 01200 = aluminium enclosure only and 00124 = stainless steel enclosure only. Please note that if any other special build is included, then these suffix numbers will change.

2.7 Tighten the cover retaining screws hand tight using a standard size Allen key / screw driver as indicated below:

- 8800 series uses a 4 mm A/F Allen key
- 889A series uses a 4 mm Allen key or correctly sized flat blade screwdriver.

3 PRODUCT REPAIR AND SERVICE

- 3.1** Inspection of this product shall be carried out by periodically by suitably trained personnel in accordance with the applicable code of practice such as EN 60079-17 to ensure that it is maintained in a satisfactory condition.
- 3.2** The equipment is not intended to be repaired by the user. The repair of this equipment is to be carried out by the manufacturer, or their approved agents, in accordance with the applicable code of practice such as EN 60079-19.
- 3.3** The equipment contained within this product can be replaced with like for like parts / assemblies.
- 3.4** The certification of this product has been approved based on the material of construction as per the drawings listed in the schedule within this certificate. Any replacement parts that are not made in accordance to the listed drawing will invalidate the approval / certification.
- 3.5** Replacement parts must be purchased through Westlock Controls UK Ltd or via an approved Westlock Controls distributor.

FIGURE 3

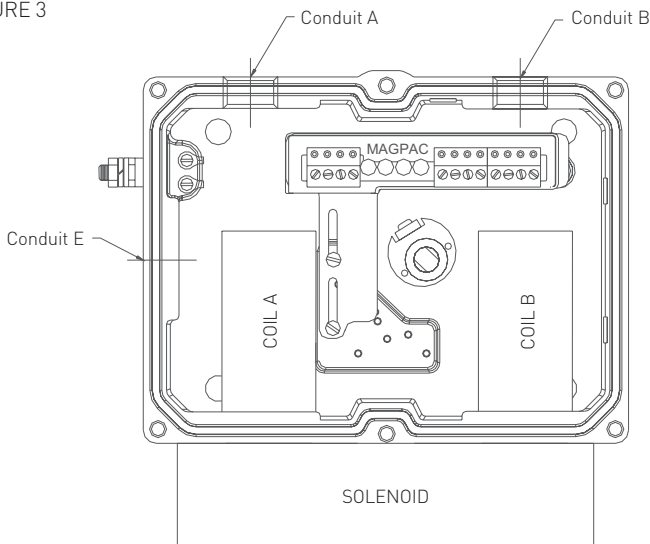

4 OPERATING AND MAINTENANCE
INSTRUCTIONS FOR FALCON AND FALCON II
SOLENOID VALVE

4.1 General description

4.1.1 The Falcon and Falcon II solenoid valve incorporates elastomer static seals through which a shaped spool moves and are manufactured for 3/2 or 5/2 way operation. 3/2 way is normally used for pilot control of the other relay valves or for the operation of single acting cylinders. 5/2 way is normally used to control the action of double acting cylinders. The seal spacer assembly forms individual annular chambers opposite each valve port and the grooved spool either closes or allows flow between adjacent chambers, hence the position of the spool determines which ports are open or closed. The spool is moved by way of a manually or mechanically operated mechanism normally against a return spring. Operation may be by application or removal of a pilot air supply acting as a pilot piston. This form of control is utilized for electrical actuation where integral solenoid valves control the pilot air supply.

4.1.2 Optional features (Falcon II)

N - No-voltage release (latching)

With the coil first energized, the palm button is then manually moved and latched. The inward movement of the palm button causes the valve to shift. When the coil is de-energized, the palm button and latching mechanism are automatically tripped, allowing the valve to return to its original position. see Figure 4.

R - No-voltage release (non-latching)

With the coil first energized, the palm button is then manually moved. The inward movement of the palm button causes the valve to shift. When the coil is de-energized, the palm button automatically returns to its original position. see Figure 5.

L - Manual locking override

Manually depress palm button and rotate clockwise for maintained condition, must manually disengage to return to original position. See Figure 6.

M - Momentary override

Spring return momentary push type, must hold in to actuate. See Figure 7.

H - Hex drive maintained override

Insert allen key in hex head screw and rotate clockwise (4-5 turns) to shift spool. Valve will stay put until hex head screw is rotated counter clockwise (4-5 turns) back to original position. See Figure 8.

E - External pilot

The 1/8" NPT external pilot connection requires a separate auxiliary pressure line to the valve. This feature should be used when the controlled pressure is below the minimum 3 bar (45 psi) operating pressure.

D/C - Dual coil option

Five way valves are available with a coil/pilot valve on each end of the Falcon II valve, coil 'A' and coil 'B'. When coil 'A' is energized the valve will shift. If coil 'A' is then de-energized, the valve will remain in this position.

The valve will not return to the original state until coil 'A' is de-energized and coil 'B' is energized.

The process is the same for coil 'B'.

Notes - For dual coil valves

The valve may be in either position upon installation. Refer to the air flow diagrams and energize the appropriate coil (with air) to reset valve to the desired position.

Dual coil valves require both an electrical signal and air pressure to operate. See air flow diagram for air pressure requirements.

If either or both inputs are lost the valve will remain in it's current position.

Both coils should never be energized simultaneously.

FIGURE 4

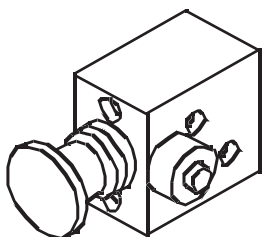

FIGURE 5

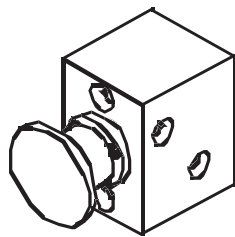

FIGURE 6

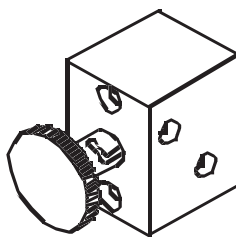

FIGURE 7

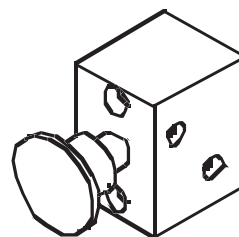
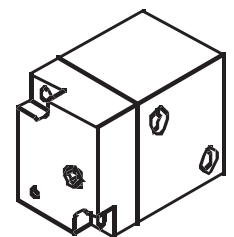

FIGURE 8



4.1.3 *Optional features (Falcon II II)*

N - No-voltage release (latching)

With the coil first energized, the palm button is then manually moved and latched. The inward movement of the palm button causes the valve to shift. When the coil is de-energized, the palm button and latching mechanism are automatically tripped, allowing the valve to return to its original position. See Figure 9.

L - Manual locking override

Manually depress palm button and rotate clockwise for maintained condition, must manually disengage to return to original position. See Figure 10.

M - Momentary override

Spring return momentary push type, must hold in to actuate. See Figure 11.

H - Hex drive maintained override

Insert allen key in hex head screw and rotate clockwise (4-5 turns) to shift spool. Valve will stay put until hex head screw is rotated counter clockwise (4-5 turns) back to original position. See Figure 12.

D/C - Dual coil option

Five way valves are available with a coil/pilot valve on each end of the Falcon II valve, coil 'A' and coil 'B'.

When coil 'A' is energized the valve will shift. If coil 'A' is then de-energized, the valve will remain in this position.

The valve will not return to the original state until coil 'A' is de-energized and coil 'B' is energized.

The process is the same for coil 'B'.

Note - For dual coil valves

The valve may be in either position upon installation. Refer to the Air Flow Diagrams and energize the appropriate coil (with air) to reset valve to the desired position.

Dual coil valves require both an electrical signal and air pressure to operate. See air flow diagram for air pressure requirements.

If either or both inputs are lost the valve will remain in its current position.

Both coils should never be energized simultaneously.

FIGURE 9

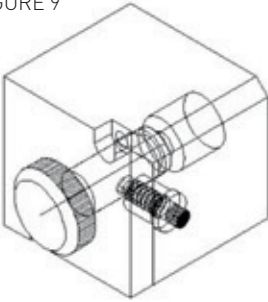

FIGURE 10

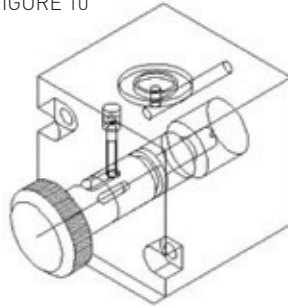

FIGURE 11

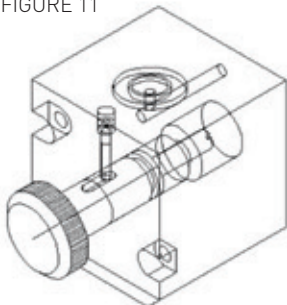
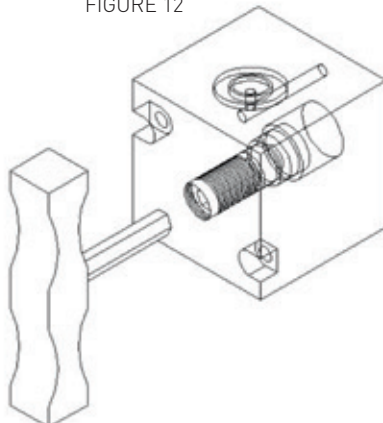
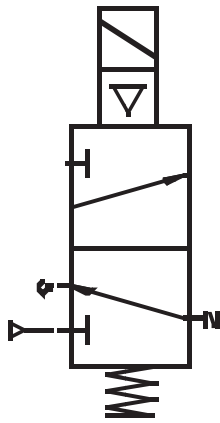

FIGURE 12





Spring return valve

Description of operation:
 Solenoid de-energized - Air flows from outlet port 2 to exhaust port 3.
 Solenoid energized - Air flows from inlet port 1 to outlet port 2.

Air line designation
 1/4" NPT or BSP air ports for inlet, outlet and exhaust

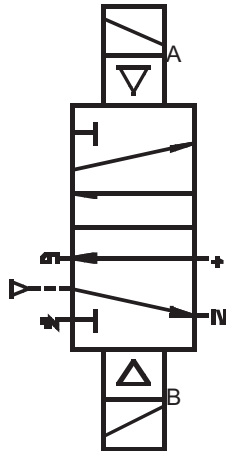

Dual coil valve

Description of operation:
 Coil B de-energized - Air flows from inlet port 1 to outlet port 2 and exhausts from port 4 to 5.
 Coil 'A' energized - Air flows from inlet port 1 to outlet port 4 and exhausts from port 2 to 3.

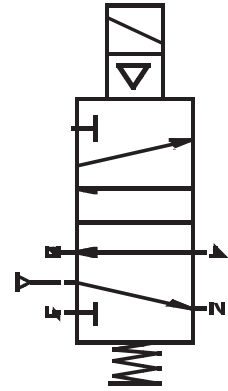

Spring return valve

Description of operation:
 Solenoid de-energized - Air flows from inlet port 1 to outlet port 2 and exhausts from port 4 to 5.
 Solenoid energized - Air flows from inlet port 1 to outlet port 4 and exhausts from port 2 to 3.

4.2 Specifications

Operating pressure: 3 - 8 bar (45-120 psig)
 Operating temperature: -20°C to 65°C (I/S only)
 -20°C to 82°C
 Operating media: Non lubricated filtered air to 20 microns

To help in preventing condensed moisture from reaching the point of usage, down pipes should never be taken directly from the bottom of air pipes or mains. Connection should be made at the top of the main and a long radius return bend used.

4.3 Field wiring

Complete the electrical wiring in accordance with National and local Electrical requirements. The ground wire should be secure under the green screw. Check all screws for tightness.

4.5 Air flow

Pipe sizes are normally determined on semi empirical lines, basis for selection being an acceptable pressure drop e.g. not more than 10% of the applied pressure. In sizing pipes, consideration should be given to likely future demands, as a system will be inefficient if the demand outgrows the supply. It is always better to over size mains as this will reduce air velocity and make water separation more effective.

4.4 (Air line) installation considerations

Air mains and lines should be large enough to avoid excessive pressure loss under conditions of maximum flow. Air lines should be installed with as few restrictions as possible if the cost of compressed air is to be kept to a minimum. Sharp turns in piping should be avoided for more efficient air flow and economical air power. It is advisable to pitch the mains in the direction of air flow so that both gravity and air flow will carry the water to traps or water legs located at frequent intervals.

4.6 Air service equipment

The importance of proper filtration (20 micron) and lubrication of the air supply to pneumatic equipment can never be over-emphasized as a means of decreasing friction and preventing corrosion and wear due to moisture and abrasive solids being present in the air supply. At higher pressures than recommended, pneumatic equipment can wear excessively with no significant increase in output and compressed air is consequently wasted. There is much to be gained, therefore, from providing pneumatic equipment with serviced air by including suitable air line filters, pressure regulators and lubricants in the installation.

4.7 Tubes and fittings

The use of copper, stainless steel, nylon or polyethylene tube is recommended for piping up air circuits and equipment. As a general rule, pipe threaded fittings should not be assembled to a specific torque because the torque required for a reliable joint varies with thread quality, port and fitting materials, sealant used, and other factors. The suggested method of assembling pipe threaded connections is to assemble them finger tight and then wrench tighten further to a specified number of turns from finger tight. The assembly procedure given below is for reference only, the fitting should not be over tightened for this will lead to distortion and most likely, complete valve failure.

1. Inspect port and connectors to ensure that the threads on both are free of dirt, burrs and excessive nicks.
2. Apply sealant/lubricant or PTFE tape to the male pipe threads. With any sealant tape, the first one or two threads should be left uncovered to avoid system contamination.
3. Screw the connector into the port to the finger tight position.
4. Wrench tighten the connector approximately 1-2 turns (to seal) from finger tight. again this is only reference - the fitting should NOT be over tightened.

Special notice

Delrin valve bodies are fitted with hellicoil therefore an extra effort should be made NOT to overtighten pipe fittings or retaining screws (0.5-1 turns from finger tight to seal). Overtightening will result in valve failure or pull hellicoil from valve body.

Maintenance

Routine maintenance is usually confined to the periodic replenishment of dow corning III lubricant or equivalent to spool and spring.

8800/889 SERIES
INSTALLATION AND OPERATING INSTRUCTIONS

EXPLODED ASSEMBLY OF 3 AND 5 WAY 1.1 C_v FALCON II

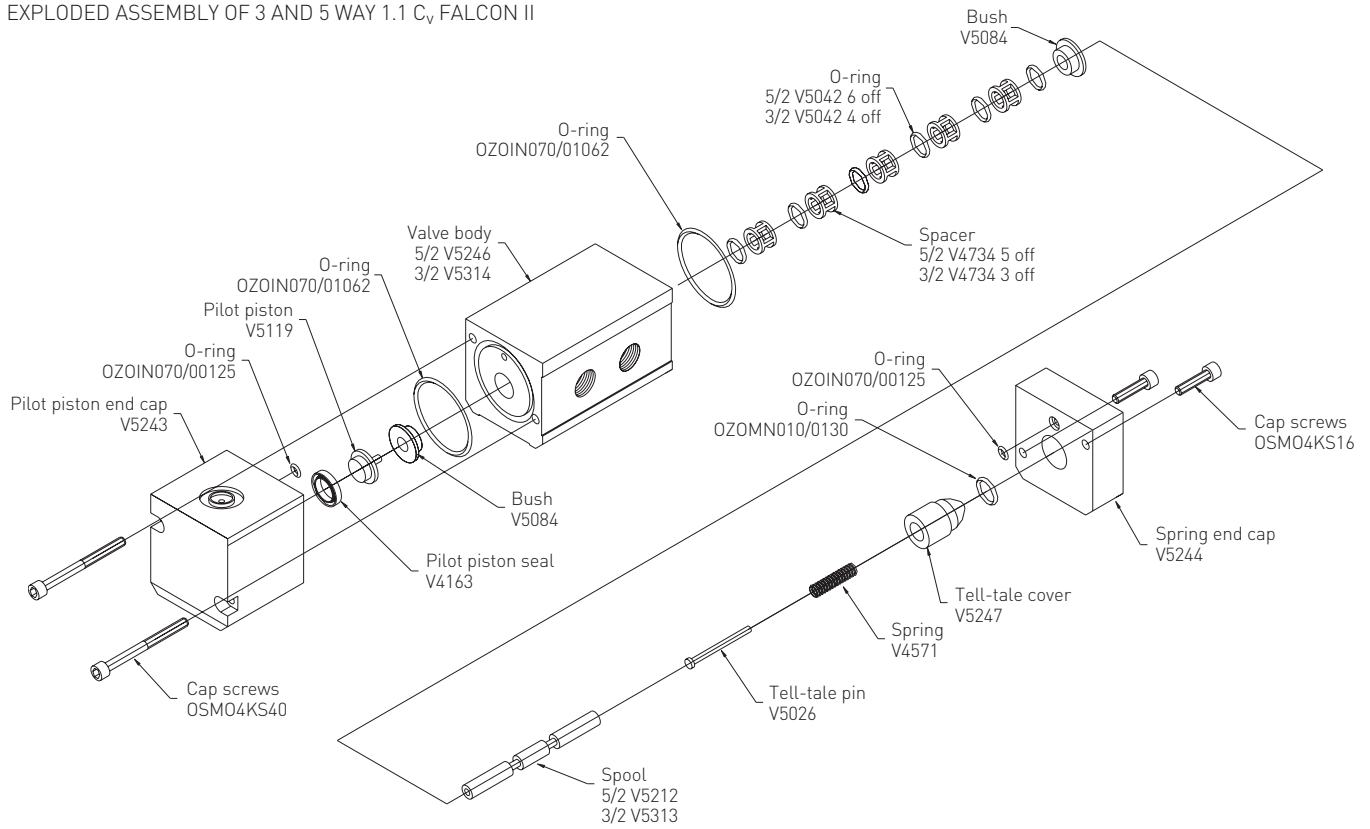

Solenoid valve and coil specification

Type:	<input type="checkbox"/> 3/2 way	<input type="checkbox"/> 5/2 way			
C _v :	<input type="checkbox"/> 0.5	<input type="checkbox"/> 0.7	<input type="checkbox"/> 1.1	<input type="checkbox"/> 1.2	<input type="checkbox"/> 3.5
Material:	<input type="checkbox"/> Alu.	<input type="checkbox"/> Brass	<input type="checkbox"/> Stainless steel		
Connection:	<input type="checkbox"/> 1/4" NPT	<input type="checkbox"/> 1/2" NPT	<input type="checkbox"/> 1/4" BSP		
Operating pressure range:	45-120 psig				
Orifice size:	1/4"				
Supply type:	<input type="checkbox"/> VAC	<input type="checkbox"/> VDC			
Supply voltage:	<input type="checkbox"/> 24	<input type="checkbox"/> 48	<input type="checkbox"/> 110/120	<input type="checkbox"/> 125	<input type="checkbox"/> 220/240
Consumption:	<input type="checkbox"/> 0.5 W	<input type="checkbox"/> 0.8 W	<input type="checkbox"/> 2.8/3.8 W	<input type="checkbox"/> 1.0 W	<input type="checkbox"/> 3.5/4.3 W
Operating current:	<input type="checkbox"/> 22 mA	<input type="checkbox"/> 12.5 mA	<input type="checkbox"/> 28/35 mA	<input type="checkbox"/> 8.5 mA	<input type="checkbox"/> 17.5/17 mA

These installation and operating instructions are based on document TECHUK-49 Rev 0 used for ATEX certification of the Westlock 8800/889 Series

Translations

Where translated the copy is taken from the original English document VCIOM-04111-EN as checked by the relevant notified certification body and therefore the original English document will prevail. No rights or liability can be derived from any translation.