

# Flow Measurement

## SITRANS F US Clamp-on

### Clamp-on ultrasonic flowmeters

#### Overview

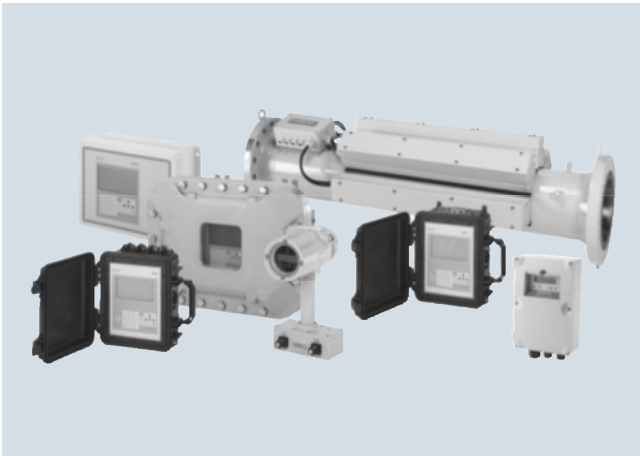

SITRANS F US clamp-on ultrasonic flowmeters provide highly accurate measurement while minimizing installation time and maintenance expense.

#### Benefits

- Easy installation; no need to cut pipe or stop flow
- Minimal maintenance; external sensors do not require periodic cleaning
- No moving parts to foul or wear
- No pressure drop or energy loss
- Wide turn-down ratio
- Choice of single, dual or multiple channel versions and a variety of enclosures - to suit your operating conditions and requirements

#### Application

SITRANS F US clamp-on ultrasonic flowmeters have seven product families, each targeting specific applications:

**SITRANS FUS1010 Standard and SITRANS FUP1010 Portable flowmeters** are suitable for a wide variety of liquid applications, including the following:

- Water industry
  - Raw water
  - Potable water
  - Chemicals
- Wastewater industry
  - Raw sewage
  - Effluent
  - Sludges
  - Mixed liquor
  - Chemicals
- HVAC industry
  - Chillers
  - Condensers
  - Hot & cold water systems
- Power industry
  - Nuclear
  - Fossil
  - Hydroelectric
- Processing industry
  - Process control
  - Batching
  - Rate indication
  - Volumetric and mass measurement

**SITRANS FUE1010 Energy flowmeters** are ideally suited to thermal energy/power industry applications, including:

- Chilled water sub-metering
- Hot water sub-metering
- Condenser water
- Glycol
- Thermal storage
- Lake source cooling

**SITRANS FUH1010 Oil flowmeters** are ideal for applications carrying crude oil, refined petroleum or liquefied gas. There are three application areas: Interface detection, precision volume and standard volume.

#### Interface detection

- Precise identification of interfaces on multi-liquid pipelines
- Rapid and precise scraper "pig" indication
- Product identification
- Density indication

#### Precision volume

- Applications with multiple liquids having a wide viscosity range
- Automatic gross volume compensation due to viscosity changes

#### Standard volume

- Standard (net) volume flow measurement
- Suitable for use in leak detection systems
- Mass flow output measurement
- Interface detection
- Scraper ("pig") detection
- Chemical and petrochemical processing

**SITRANS FUG1010 Gas flowmeters** are ideal for most natural and process gas industry applications, including:

- Checkmetering
- Allocation
- Flow survey verification
- Lost and unaccounted for (LAUF) analysis
- Production
- Storage

**SITRANS FST020 Basic flowmeters** are suitable for most clean liquid applications, including the following:

- Water & wastewater industry
  - Potable water
  - Wastewater, influent & effluent
  - Processed sewage, sludge
- Chemical feed industry
  - Sodium hypochlorite
  - Sodium hydroxide
- HVAC & power industries
  - Coolant flow
  - Fuel flow
- Process control
  - Chemicals
  - Pharmaceuticals

**SITRANS FUT1010 Liquid and gas flowmeters** are suitable for liquid and gas applications, including the following:

- Liquid
  - Pipeline balancing
  - Terminal transmix metering
  - Refinery blending
  - Airport facility management
  - Petrochemical processing
  - Plant optimization
- Gas
  - Production wells
  - Underground storage
  - Transmission
  - Electric power generation
  - Gas processing plants

# Flow Measurement

## SITRANS F US Clamp-on

### System information SITRANS F US Clamp-on ultrasonic flowmeters

#### System information and selection guide

SITRANS F US Clamp-on flowmeters	FUS1010 (Standard)	FST020 (Basic)	FUP1010 (Portable)	FUE1010 (Energy)	FUH1010 (Oil)	FUG1010 (Gas)	FUT1010 (Liquid/Gas)
<b>Industry/Applications</b>							
Water and aqueous solutions	X	X	X	X			
Utility district heating, cooling	X	X	X	X			
Chemical	X	X	X				
Hydrocarbons/Petrochemical, multiple products or varying viscosity, liquefied gases, net and gross volume					X		X
Hydrocarbons (Single product with limited viscosity range) gross volume	X		X		X		X
Very low flow (< 0.1 m/s) in small pipes	X	X	X				
Natural gas						X	X
Process gas						X	X
Slurries or liquids with high percentage of undissolved gases	X <sup>4)</sup>		X	X			
High temperature liquids > 120 °C (248 °F)	X <sup>1)</sup>	X <sup>1)</sup>	X <sup>1)</sup>	X <sup>1)</sup>	X <sup>1)</sup>		
Aerospace or hydraulic test	X <sup>2)</sup>		X <sup>2)</sup>				
Refrigeration liquids	X	X	X	X			
Food products	X	X	X				
<b>Design</b>							
Field clamp-on (non-intrusive)	X	X	X	X	X	X	X
Doppler (Reflexor) hybrid capability	X <sup>4)</sup>		X	X			
Standard volume or mass flow; per API 2540					X		X
Interface detection					X		X
Density output					X		X
Standard volume or mass flow; per AGA 8						X	X
Differential temperature with energy calculation				X			
Temperature measurement	X		X	X	X	X	X
Analog input	X		X	X	X	X	X
Large graphics display	4)		X	X	4)	4)	X
Diagnostic PC software (Si-Ware)	X	X	X	X	X	X	X
<b>Number of acoustic paths and channels</b>							
1-channel	X	X	X	X	X	X	X
2-path	X		X	X	X	X	X
2-channel w/arithmetic function	X		X	X			
4-path/(special order)	X				X	X	X
4-channel w/sum of active channels	X						
<b>Transmitter enclosure</b>							
IP65 (NEMA 4X) wall mount	X	X		X	X	X	X
IP67 weatherproof			X				
IP40 (NEMA 1) portable				X <sup>3)</sup>			
IP65 (NEMA 7) compact explosionproof	X				X	X	
IP66 (NEMA 7) wall mount explosion-proof	X				X	X	X

1) Special order high temperature clamp-on sensor

2) Special order Aerospace clip-on sensor recommended

3) Available with portable energy systems

4) Not for NEMA 7 compact explosionproof

# Flow Measurement

## SITRANS F US Clamp-on

System information SITRANS F US  
Clamp-on ultrasonic flowmeters

SITRANS F US Clamp-on flowmeters	FUS1010 (Standard)	FST020 (Basic)	FUP1010 (Portable)	FUE1010 (Energy)	FUH1010 (Oil)	FUG1010 (Gas)	FUT1010 (Liquid/Gas)
<b>Power Supply</b>							
Internal battery operation			X	X <sup>1)</sup>			
Battery charger (100 ... 240 V AC 50 ... 60 Hz) with country specific line cord			X	X <sup>1)</sup>			
90 ... 240 V AC, 50 ... 60 Hz	X	X		X	X	X	X
9 ... 36 V DC <sup>4)</sup>	X	X		X	X	X	X
<b>Size (For larger pipes, see spares list for appropriate sensors and mountings.)</b>							
6.5 ... 9150 mm (0.25" ... 360.24")	X	X	X				
38 ... 9150 mm (1.5" ... 360.24")				X	X	X	
<b>Approvals</b>							
FM/CSA <sup>2)5)</sup>	X			X <sup>3)</sup>	X	X	X
ATEX <sup>5)</sup>	X				X	X	X
UL/ULC <sup>5)</sup>		X	X	X			
INMETRO <sup>5)</sup>	X			X	X	X	X
C-TICK <sup>5)</sup>	X	X		X	X	X	

<sup>1)</sup> Available with portable energy systems

<sup>2)</sup> NEMA 4X associated equipment in DIV 2 connected to DIV 1 sensors, NEMA 7 explosionproof equipment in DIV 1 connected to DIV 1 sensors.

<sup>3)</sup> Not for portable enclosure

<sup>4)</sup> -Neg and +pos ground available for compact NEMA 7

<sup>5)</sup> Products are marked with CE as required by european directive.

### Sensor type selection guide

Application condition. Note all that apply before making selection	Standard sensor supported in MLFB			Notes
	High precision	Universal	(Reflexor)	
<b>Media</b>				
General survey (clean liquids) on non-steel pipes		X	O	
General survey (clean liquids) on a limited range of steel pipes	X		O	
Moderately aerated liquid or slurry, up to 121 °C (250 °F)	X			
Highly aerated liquid or slurry	O	O	X	
Permanent installation on steel pipe (clean liquids)	X		O	
Installation in offshore or corrosive environment	O	X <sup>1)</sup>	O	Sensors available with corrosion resistance as special order
Liquid temperature greater than 120 °C (248 °F)	O	X <sup>1)</sup>		High temp metal block sensors available as special order (to 230 °C (446 °F))
Operation on single pipeline flowing multiple products	X	O		
Natural gas or process gas	X	O	O	Consult sales specialist for all gas applications
<b>Pipe material</b>				
Steel	X		O	
Steel pipe with diameter/wall thickness ratio <10	O	X		
Non-steel pipe material (copper, ductile iron, cast iron, etc.)	O	X		High precision sensors can also be used on plastic and aluminum pipes
Wall thickness > 31.75 (1.25")	O	X		

O = not suitable X = preferred choice

<sup>1)</sup> Available for special order

# Flow Measurement

## SITRANS F US Clamp-on

### System information SITRANS F US Clamp-on ultrasonic flowmeters

#### Definitions

Sensor Chart	Description
Standard	Standard system sensor, plastic body with alu housing, FM, CE
Spare	Available for special application and special pipes. Contact factory for application use. Not available as part of a configured product
Gas	Usable for gas application. Available also as corrosion resistant, frame, track or weldseal mounting, T1, T2. FM, ATEX, CE
CE	All flowmeter and sensors are CE - certified
Ex-FM	Standard, corrosion resistant, frames, weldseal, T1, T2, T3
Ex-ATEX	Option for all corrosion resistant, frames, weldseal, T1, T2, T3
Corrosion resistant	SS Housing instead Alu
Trackless	Fixed only by straps, no other mounting (spacer bar as an option)
Tracks	Portable and dedicated for universal size A/B and for HP size A/B. For all size HT only dedicated
Frames	Portable and dedicated for universal size C,D,E, and for HP size C/D. For universal and HP size B available for pipes >125 OD
Portable	BNC insted F-connector. Mounting universal sensor by portable tracks, frames and spacerbar
Transportable	Dedicated sensor including adapter for portable BNC cables.
WeldSeal	Special SS Frames for FUH1010,FUG1010, but also special FUS1010. Corrosion resistant, Liquid and Gas, T1, T2
T1	Usable -40 to 120°C, but best for Ø Temperature <40°C; Standard
T2	Usable -40 to 120°C, but best for Ø Temperature >40°C - <80°C; Named as high temperature high precision
T3	Usable -40 to 120°C, but best for Ø Temperature >80°C; special request
Submersible	Transducers can be used submersible by denso.

#### Sensor availability guide

Sensor models	Availability																	
	Standard	Spare only	Gas	Ex-ATEX	Ex-FM	Corrosion resistant	Trackless	Tracks	Frames	Portable	Transportable	WeldSeal	T1 (best use -40 ... 65 °C)	T2 (best use1 ... 104 °C)	T3 (best use 32 ... 120 °C)	Submersible	Cataloge	
<b>Universal Sensor -40 ... 120 °C Alu housing CE IP68</b>																		
A1 Universal for pipe OD – 5,8 ... 50,8 mm (0.23" ... 2")		X		X <sup>1)</sup>	X <sup>1)</sup>	X <sup>1)</sup>	X <sup>3)</sup>	X		X							X <sup>1)</sup>	
A2 Universal for pipe OD – 12,7 ... 50,8 mm (0.5" ... 2")	X			X <sup>1)</sup>	X <sup>1)</sup>	X <sup>1)</sup>	X <sup>3)</sup>	X		X							X <sup>1)</sup> 2)	X
B1 Universal for pipe OD – 12,7 ... 76 mm (0.5" ... 3")		X		X <sup>1)</sup>	X <sup>1)</sup>	X <sup>1)</sup>	X <sup>3)</sup>	X	X	X							X <sup>1)</sup>	
B2 Universal for pipe OD – 12,7 ... 76 mm (0.5" ... 3")		X		X <sup>1)</sup>	X <sup>1)</sup>	X <sup>1)</sup>	X <sup>3)</sup>	X	X	X							X <sup>1)</sup>	
B3 Universal for pipe OD – 19 ... 127 mm (0.75" ... 5")	X			X <sup>1)</sup>	X <sup>1)</sup>	X <sup>1)</sup>	X <sup>3)</sup>	X	X	X							X <sup>1)</sup> 2)	X
C1 Universal for pipe OD – 51 ... 254 mm (2" ... 10")		X		X <sup>1)</sup>	X <sup>1)</sup>	X <sup>1)</sup>	X		X	X							X <sup>1)</sup>	
C2 Universal for pipe OD – 51 ... 254 mm (2" ... 10")		X		X <sup>1)</sup>	X <sup>1)</sup>	X <sup>1)</sup>	X		X	X							X <sup>1)</sup>	
C3 Universal for pipe OD – 51 ... 305 mm (2" ... 12")	X			X <sup>1)</sup>	X <sup>1)</sup>	X <sup>1)</sup>	X		X	X							X <sup>1)</sup> 2)	X
D1 Universal for pipe OD – 102 ... 508 mm (4" ... 20")		X		X <sup>1)</sup>	X <sup>1)</sup>	X <sup>1)</sup>	X		X	X							X <sup>1)</sup>	
D2 Universal for pipe OD – 152 ... 610 mm (6" ... 24")		X		X <sup>1)</sup>	X <sup>1)</sup>	X <sup>1)</sup>	X		X	X							X <sup>1)</sup>	
D3 Universal for pipe OD – 203 ... 610 mm (8" ... 24")	X			X <sup>1)</sup>	X <sup>1)</sup>	X <sup>1)</sup>	X		X	X							X <sup>1)</sup> 2)	X
*E1 Universal for pipe OD – 254 ... 3048 mm (10" ... 120")		X		X <sup>1)</sup>	X <sup>1)</sup>	X <sup>1)</sup>	X		X	X							X <sup>1)</sup>	
*E2 Universal for pipe OD – 254 ... 6096 mm (10" ... 240")	X			X <sup>1)</sup>	X <sup>1)</sup>	X <sup>1)</sup>	X		X	X							X <sup>1)</sup> 2)	X
*E3 Universal for pipe OD – 304 ... 9144 mm (12" ... 360")		X	X <sup>1)</sup>	X <sup>1)</sup>	X <sup>1)</sup>	X <sup>1)</sup>	X		X	X		X <sup>1)</sup>					X <sup>1)</sup>	

<sup>1)</sup> Excluding portable

<sup>2)</sup> Spare only

<sup>3)</sup> Usable but not recommended

# Flow Measurement

## SITRANS F US Clamp-on

System information SITRANS F US  
Clamp-on ultrasonic flowmeters

Sensor models	Availability																
	Standard	Spare only	Gas	Ex-ATEX	Ex-FM	Corrosion resistant	Trackless	Tracks	Frames	Portable	Transportable	WeldSeal	T1 (best use -40 ... 65 °C)	T2 (best use1 ... 104 °C)	T3 (best use 32 ... 120 °C)	Submersible	Cataloge
<b>High Precision Sensor -40 ... +120 °C Alu T1 (T2, T3) CE IP68</b>																	
A1H (High Precision) for pipe WT - 0.64 ... 1.0 mm (0.025" ... 0.04")		X	X <sup>1)</sup>	X <sup>1)</sup>	X <sup>1)</sup>	X <sup>1)</sup>	X <sup>3)</sup>	X			X		X	X	X	X <sup>1)</sup>	X
A2H (High Precision) for pipe WT - 1.0 ... 1.5 mm (0.04" ... 0.06")	X		X <sup>1)</sup>	X <sup>1)</sup>	X <sup>1)</sup>	X <sup>1)</sup>	X <sup>3)</sup>	X		X		X	X	X	X	X <sup>1) 2)</sup>	X
A3H (High Precision) for pipe WT - 1.5 ... 2.0 mm (0.06" ... 0.08")	X		X <sup>1)</sup>	X <sup>1)</sup>	X <sup>1)</sup>	X <sup>1)</sup>	X <sup>3)</sup>	X		X		X	X	X	X	X <sup>1) 2)</sup>	X
B1H (High Precision) for pipe WT - 2.0 ... 3.0 mm (0.08" ... 0.12")	X		X <sup>1)</sup>	X <sup>1)</sup>	X <sup>1)</sup>	X <sup>1)</sup>	X <sup>3)</sup>	X	X		X		X	X	X	X <sup>1) 2)</sup>	X
B2H (High Precision) for pipe WT - 3.0 ... 4.1 mm (0.12" ... 0.16")	X		X <sup>1)</sup>	X <sup>1)</sup>	X <sup>1)</sup>	X <sup>1)</sup>	X <sup>3)</sup>	X	X		X		X	X	X	X <sup>1) 2)</sup>	X
B3H (High Precision) for pipe WT - 2.7 ... 3.3 mm (0.106" ... 0.128")		X	X <sup>1)</sup>	X <sup>1)</sup>	X <sup>1)</sup>	X <sup>1)</sup>	X <sup>3)</sup>	X	X		X		X	X	X	X <sup>1)</sup>	X
C1H (High Precision) for pipe WT - 4.1 ... 5.8 mm (0.16" ... 0.23")	X		X <sup>1)</sup>	X <sup>1)</sup>	X <sup>1)</sup>	X <sup>1)</sup>	X		X		X	X <sup>1)</sup>	X	X	X	X <sup>1) 2)</sup>	X
C2H (High Precision) for pipe WT - 5.8 ... 8.1 mm (0.23" ... 0.32")	X		X <sup>1)</sup>	X <sup>1)</sup>	X <sup>1)</sup>	X <sup>1)</sup>	X		X		X	X <sup>1)</sup>	X	X	X	X <sup>1) 2)</sup>	X
* D1H (High Precision) for pipe WT - 8.1 ... 11.2 mm (0.32" ... 0.44")		X	X <sup>1)</sup>	X <sup>1)</sup>	X <sup>1)</sup>	X <sup>1)</sup>	X		X		X	X <sup>1)</sup>	X	X	X	X <sup>1) 2)</sup>	X
* D2H (High Precision) for pipe WT - 11.2 ... 15.7 mm (0.44" ... 0.62")		X	X <sup>1)</sup>	X <sup>1)</sup>	X <sup>1)</sup>	X <sup>1)</sup>	X		X		X	X <sup>1)</sup>	X	X	X	X <sup>1) 2)</sup>	X
* D3H (High Precision) for pipe WT - 7.4 ... 9.0 mm (0.293" ... 0.354")		X	X <sup>1)</sup>	X <sup>1)</sup>	X <sup>1)</sup>	X <sup>1)</sup>	X		X		X	X <sup>1)</sup>	X	X	X	X <sup>1)</sup>	X
* D4H (High Precision) for pipe WT - 15.7 ... 31.8 mm (0.62" ... 1.25")		X	X <sup>1)</sup>	X <sup>1)</sup>	X <sup>1)</sup>	X <sup>1)</sup>	X		X		X	X <sup>1)</sup>	X	X	X	X <sup>1) 2)</sup>	X
<b>High Temperature Universal Sensor -40 ... +230 °C</b>																	
High Temperature size 1 ... 230 deg C (diam. 12.7 ... 100 mm)		X		X <sup>1)</sup>	X <sup>1)</sup>			X			X						
High Temperature size 2 ... 230 deg C (diam. 30 ... 200 mm )		X		X <sup>1)</sup>	X <sup>1)</sup>			X			X						X
High Temperature size 3 ... 230 deg C (diam. 150 ... 610 mm)		X		X <sup>1)</sup>	X <sup>1)</sup>			X			X						X
High Temperature size 4 ... 230 deg C (diam. 400 ... 1200 mm)		X		X <sup>1)</sup>	X <sup>1)</sup>			X			X						X
High Temperature size 2A ... 230 deg C (diam. 30 ... 200 mm)		X		X <sup>1)</sup>	X <sup>1)</sup>			X			X						
High Temp. size 3A ... 230 deg C (diam. 150 ... 610 mm)		X		X <sup>1)</sup>	X <sup>1)</sup>			X			X						
High Temp. size 4A ... 230 deg C (diam. 400 ... 1200 mm)		X		X <sup>1)</sup>	X <sup>1)</sup>			X			X						
<b>Doppler Sensor</b>																	
Doppler Sensor, for up to 121 °C (250 °F)		X		X <sup>1)</sup>	X <sup>1)</sup>		X		X							X <sup>1)</sup>	X
Corrosion Resistant Doppler, for up to 121 °C (250 °F)		X		X <sup>1)</sup>	X <sup>1)</sup>	X <sup>1)</sup>	X										

<sup>1)</sup> Excluding portable

<sup>2)</sup> Spare Only

<sup>3)</sup> Useable but not recommended

# Flow Measurement

## SITRANS F US Clamp-on

System information SITRANS F US  
Clamp-on ultrasonic flowmeters

### Sensor mounting availability guide

	Sensor							
	Universal NEMA	Universal portable	WeldSeal sensors	Dedicated gas and liquid flow HP sensors	Portable liquid flow HP sensors	High temperature universal sensors	Doppler NEMA	Doppler portable
<b>Montage</b>								
Trackless	X	X		X	X		X	X
Tracks universal dedicated	X	X <sup>1)</sup>						
Tracks universal portable	X <sup>1)</sup>	X						
Tracks HP dedicated				X	X <sup>1)</sup>			
Tracks HP portable				X <sup>1)</sup>	X			
Frames universal dedicated	X	X <sup>1)</sup>						
Frames universal portable	X <sup>1)</sup>	X						
Frames HP dedicated				X	X <sup>1)</sup>			
Frames HP portable				X <sup>1)</sup>	X			
Tracks high temp universal						X		
WeldSeal single enclosure			X					
WeldSeal dual enclosure			X					
SpacerBar	X	X		X	X			
Straps	X	X <sup>1)</sup>		X	X <sup>1)</sup>	X	X	X <sup>1)</sup>
Chains tension hook		X			X			
Chains EZ-Clamp 1	Size C, D	Size C, D		Size C	Size C			
Chains EZ-Clamp 2	Size E	Size E		Size D	Size D			
Denso	X			X			X	
Doppler-Chains								X

<sup>1)</sup> Useable but not recommended

#### Input/output and function availability guide

			Output							Input												
			Standard	Additional inputs	Expanded/Enhanced	4 ... 20 mA active	4 ... 20 mA passive	0 ... 10 V	0 ... 5 kHz	p-gen (20 ... 40 kHz)	Relais - Dry reed	Status alarm	4 ... 20 mA passive	0 ... 10 V	100 Ohm RTD	NoTot	ClrTot	ATEX	Unimass	Modbus	Doppler	
FUS1010	NEMA 4X and NEMA 7 wall mount	Single channel	X			2		2	2		4				1	1	X		X	X		
			X	X		2		2	2		4		4		1	1	1	X	X	X	X	
		Dual channel	X			2 <sup>3)</sup>		2	2		4 <sup>4)</sup>					2	2	X		X	X	
				X		2 <sup>3)</sup>	4 <sup>4)</sup>	2	2		4 <sup>4)</sup>					2	2	X		X	X	
		Dual path	X			2		2	2		4					1	1	X		X	X	
			X	X		2		2	2		4		4		1	1	1	X	1	X	X	
	Four path	X			4 <sup>3)</sup>	4 <sup>3)1)</sup>				4					4		X		X			
		X	X		4 <sup>3)</sup>	4 <sup>3)1)</sup>				4 <sup>3)</sup>		4		1	4		X	4	X			
	Four path	X			4	4 <sup>1)</sup>				4 <sup>3)</sup>					4		X		X			
		X	X		4	4 <sup>1)</sup>				4		4		1	4		X	1	X			
	NEMA 7 compact	Single channel	X			2		2				1							X			
				X		2		2			1	1	1					X	X			
Dual channel		X			2 <sup>3)</sup>		2 <sup>3)</sup>			2 <sup>3)</sup>		2 <sup>3)</sup>						X				
		X		2 <sup>3)</sup>		2 <sup>3)</sup>			2 <sup>3)</sup>	2 <sup>3)</sup>	2					X	X					
Dual path	X			2		2			4 <sup>4)</sup>								X					
		X		2		2			4 <sup>4)</sup>	2	1					X	X					
FST020	FST020	Single channel	X			1		1			1											
FUP1010	IP67	Single channel		X		1	1	1			2										X	
		Dual channel/path		X		2 <sup>3)</sup>	2 <sup>3)</sup>	2 <sup>3)</sup>			4 <sup>4)</sup>										X	
FUE1010	NEMA 4X	Single channel	X	X		2		2	2		4		4	2	1	1	FM		X	X		
		Dual channel	X	X		2 <sup>3)</sup>		2 <sup>3)</sup>	2 <sup>3)</sup>			2 <sup>3)</sup>		2 <sup>3)</sup>	4	2	2	FM		X	X	
				X	X	2 <sup>3)</sup>		2 <sup>3)</sup>	2 <sup>3)</sup>		4 <sup>4)</sup>	2 <sup>3)</sup>		4	2	2	FM		X	X		
	Dual path	X	X		2		2	2		4		2		4	1	1	FM		X	X		
		X	X	2	4	2	2		4		2		4	1	1	FM		X	X			
Portable	Dual channel/path	X	X		2 <sup>3)</sup>	2 <sup>3)</sup>	2 <sup>3)</sup>			4 <sup>4)</sup>		2		4	2	2				X		
FUH1010	NEMA 4X and NEMA 7 wall mount	Single channel	X	X		2		2	2		4			1	1	1	X		X			
		Dual path	X	X		2		2		2	4		2		1	1	1	X		X		
				X	X <sup>2)</sup>	2	2	2		2	4		2		1	1	1	X		X		
	Four path <sup>2)</sup>	X	X		2	2	2		2	4		2		1	1	1	X		X			
	NEMA 7 compact	Single channel	X	X		1				1		1			1	1	1	X				
Dual path		X	X		2					2				1	1	1	X					
		X	X		2				1		1			1	1	1	X					
FUG1010	NEMA 4X and NEMA 7 wall mount	Single channel	X	X		2		2		2	4			1	1	1	X		X			
		Dual path		X	X	2	2	2		2	4		2		1	1	1	X		X		
		Four path		X	X	2	2	2		2	4		2		1	1	1	X		X		
	NEMA 7 compact	Single channel	X	X		1				1		1			1	1	1	X				
		Dual channel	X	X		2					2				1	1	1	X				
	X	X		2					1		1			1	1	1	X					

<sup>1)</sup> Fixed to IO adjustment

<sup>2)</sup> Not available for Interface Detector

<sup>3)</sup> One per channel

<sup>4)</sup> Two per channel



# Flow Measurement

## SITRANS F US Clamp-on

### System information SITRANS F US Clamp-on ultrasonic flowmeters

#### Function

##### Operating Principle

The SITRANS F US system is a transit-time ultrasonic meter that provides exceptional performance using a non-intrusive clamp-on approach. Ultrasonic sensors transmit and receive acoustic signals directly through the existing pipe wall, where the fluid refraction angle is governed by Snell's law of refraction.

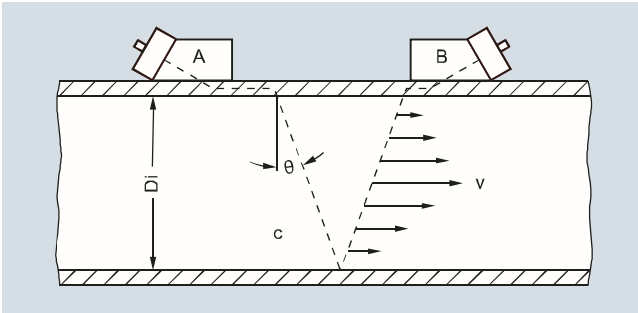

Clamp-on sensor mounted in a reflect configuration

The beam refraction angle is calculated as follows:

$$\sin\theta = c / V_{\phi}$$

$c$  = Velocity of sound in fluid

$V_{\phi}$  = Phase velocity (a constant in the pipe wall)

The flowmeter automatically compensates for any change in fluid sound velocity (or beam angle) in response to variations in the average transit time between sensors A and B. By subtracting the computed fixed times (within the sensors and pipe wall) from the measured average transit time, the meter can then infer the required transit time in the fluid ( $T_{\text{Fluid}}$ ).

The sound waves traveling in the same direction as flow ( $T_{A,B}$ ) arrive earlier than sound waves traveling against the direction of flow ( $T_{B,A}$ ). This time difference ( $\Delta t$ ) is used to compute the line integrated flow velocity ( $v$ ) as shown in the equation below:

$$v = V_{\phi} / 2 \cdot \Delta t / T_{\text{Fluid}}$$

Once the raw flow velocity is determined, the fluid Reynolds Number ( $Re$ ) must be determined to properly correct for fully developed flow profile. This requires the entry of the fluid's kinematic viscosity ( $\text{visc}$ ) as shown in the equations below, where  $Q$  represents the final flow profile compensated volumetric flow rate.

$$Re = Di \cdot v / \text{visc} \cdot Q = K(Re) \cdot (\pi / 4 \cdot Di^2) \cdot v$$

$v$  = Flow velocity

$\text{visc} = \mu / \rho$  = (dynamic viscosity / density)

$K(Re)$  = Reynolds flow profile compensation

In wetted type ultrasonic flowmeters the meter constants are configured prior to leaving the factory. As this is not possible with clamp-on meters, the settings must be made by the customer at the time of installation. These settings include pipe diameter, wall thickness, liquid viscosity, etc.

SITRANS Clamp-On flowmeters that include temperature sensing can be configured to dynamically infer changes in fluid viscosity for the purpose of computing the most accurate flow profile compensation ( $K_{Re}$ ).

##### Ultrasonic Sensor Types

Three basic types of Clamp-On sensors can be selected for use with the SITRANS F US flowmeter. The lower cost "universal" sensor is the most common type in the industry and is suitable for most single liquid applications where the sound velocity does not vary much. This sensor type can be used on any sonically conductive pipe material (including steel) making it well suited for portable survey applications. Universal sensors are selected

based on the pipe diameter range alone, so wall thickness is less important to the selection process.

The second sensor type is the WideBeam sensor (called high precision), which utilizes the pipe wall as a kind of waveguide to optimize the signal to noise ratio and provide a wider area of vibration. This makes this kind of sensor less sensitive to any change in the fluid medium.

The WideBeam sensor is designed for steel pipes, but can also be used with aluminum, titanium and plastic pipe. It is the preferred sensor for HPI and gas applications. Note that unlike the universal type, this sensor selection is dependent only on the pipe's wall thickness.

##### Automatic Zero Drift Correction (ZeroMatic Path)

When WideBeam sensors are installed in the "Reflect" mode shown below, the acoustic signal travels in two different paths between sensors A and B. One path "ACB" travels through the pipe wall and fluid, while the other path "AB" never enters the fluid medium.

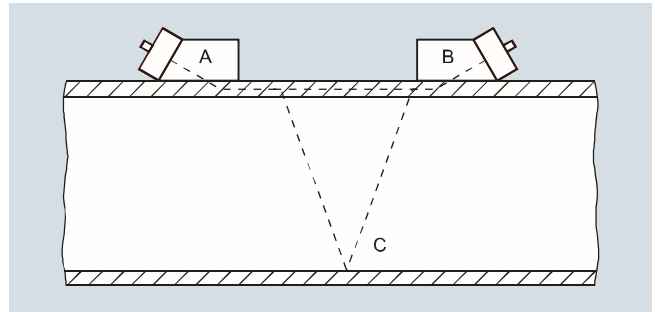

This later path provides the meter with a reference signal that is completely independent of flow rate and can therefore be used as a measure of sensor "mis-match". By continually analyzing this pipe wall signal the SITRANS FUS1010 meter can dynamically correct for flow errors caused by zero drift.

##### Multi-Channel Flowmeters

For improved flow profile averaging, redundancy or better cost per measurement, Clamp-On meters can be supplied with 2, 3 or 4 path measurement systems.

In the standard FUS, FUP, FUE systems, these channels can be installed on separate independent lines or in a multi-beam installation as shown below. This choice is made during meter setup, where either a multi-path (two paths on same pipe) or multi-channel installation can be selected.

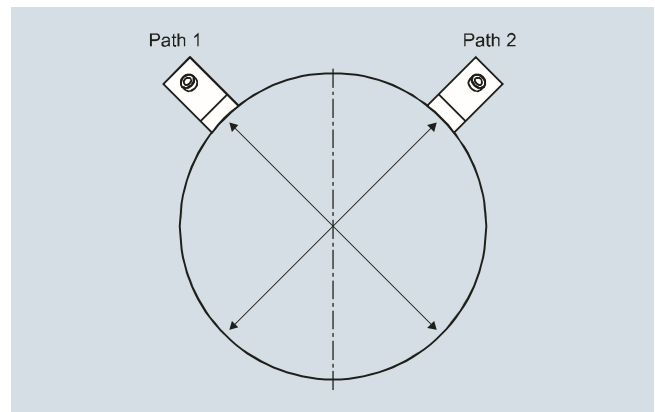

Dual path installation example

# Flow Measurement

## SITRANS F US Clamp-on

System information SITRANS F US  
Clamp-on ultrasonic flowmeters

### Doppler (Reflexor) Operation

The Doppler measurement technique relies on the reflection of sound energy off tiny gas bubbles or suspended particles to create a doppler shift in the fixed frequency acoustic transmit signal, as shown below.

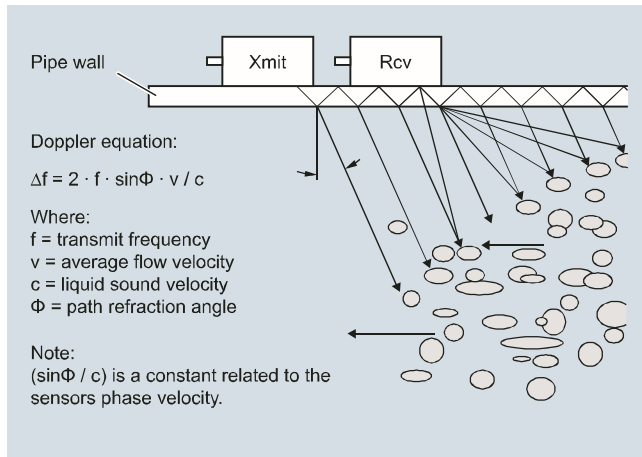

When de-demodulated using FFT signal processing, this doppler shifted frequency ( $\Delta f$ ) can be used to measure the flow rate as described in the associated doppler equations below.

Although the standard transit time measurement system is very tolerant of high levels of liquid aeration and high solids content, there will be cases where insufficient signal will be available for operation with transit time mode. For these cases the FUS, FUP and FUE meters can be ordered with this optional doppler capability, which requires an additional doppler sensor.

### SITRANS meter family description

#### SITRANS FUS1010 Standard flowmeters

The SITRANS FUS1010 system is a basic function permanent (or dedicated) clamp-on meter that is available with a full range of safety approvals, I/Os and enclosure types. This meter can be used in a wide range of applications but does not include the special functions found in the hydrocarbon FUH and energy FUE flowmeters.

The SITRANS FUS1010 meter is typically programmed with a fixed viscosity and specific gravity entry, which can limit the mass flow and volumetric flow accuracy when highly variable (multi-product) liquid properties flow through the same pipeline.

If this meter is ordered with the Type 3 hardware and program configuration, it will have the ability to accommodate clamp-on RTDs, or an analog input from a temperature transmitter. With an active measurement of liquid temperature the meter can then be programmed to compensate for changes in liquid density and viscosity by mean of a "UniMass" table (for advanced users).

#### SITRANS FST020 Basic flowmeters

The SITRANS FST020 system has the same basic function of the SITRANS FUS1010 system, but does not include the same I/O capability or safety approval rating of the SITRANS FUS1010. This basic meter is intended for single liquid applications that do not require these additional features, such as doppler and uni-mass. Note that the SITRANS FST020 is not available with hazardous area approvals.

#### SITRANS FUP1010 Portable flowmeters

The SITRANS FUP1010 meter has all the capabilities of the SITRANS FUS1010 meter, but in a battery powered portable configuration. This meter is ideal for general flow survey work where high accuracy is required. Note that the FUP meter is not available with hazardous areas approvals.

### SITRANS FUE1010 Energy flowmeters

By combining clamp-on transit time flow measurement with accurate temperature differential measurement, the SITRANS FUE1010 system provides a solution to thermal energy metering with no interruption of service. Energy measurement can be provided for water, ethylene glycol and brine solutions or steam condensate.

Absolute and differential temperature measurement is accomplished with the use of 2 matched 1 k $\Omega$  RTD elements installed on the supply and return side of the heating or cooling system. Efficiency calculation (kW/ton, EER or COP) is also available in systems with the optional analog input capability, which allow the meter to accept a power meter output.

The SITRANS FUE1010 system is available in both dedicated (IP65 (NEMA 4X)) and portable configurations (IP40).

### SITRANS FUG1010 Gas flowmeters

**Be sure to contact a Siemens clamp-on specialist before placing a gas system order.**

This unique Clamp-On gas meter uses the same WideBeam transit time operating principle described above. However, due to the very low density and sound velocity characteristics of gases, this meter requires a high gain signal amplifier and the installation of a pipe damping material.

The pipe damping material consists of an adhesive backed viscoelastic film that is designed to attenuate any stray acoustic transmit energy that may otherwise interfere with the transit time gas signal. Damping material installation requires a clean (grease free) pipe surface with well bonded paint.

The Clamp-On gas meter is capable of operation on most gases (natural gas, oxygen, nitrogen, carbon monoxide, etc) with a typical minimum operating pressure of 10 barg (145 psig). Low molecular weight gases such as helium or hydrogen can also be measured, but at a higher minimum pressure.

Standard volume computation: Can provide a standard volume or mass flow output for fixed gas compositions. All SITRANS FUG1010 Gas meters include analog input capability that can be used for pressure and temperature compensation. With the installation of an AGA8 lookup table this meter can dynamically adjust the compressibility factor ( $Z_{act}$ ) in response to changes in gas pressure and temperature, as indicate below:

$$\text{Std. Rate} = Q_{act} \cdot P_{act}/P_{base} \cdot T_{base}/T_{act} \cdot Z_{base}/Z_{act}$$

### SITRANS FUH1010 Oil flowmeters

There are three models of flowmeters included in the SITRANS FUH1010 family, a precision volume model, used for applications that will flow a wide range of viscosity, a standard volume (mass) model, and an interface detection model. All models rely on a variable referred to as "Liquident", which is used to infer the liquid's viscosity and optionally the liquid's density. This variable represents the measured liquid sonic velocity compensated by the operating temperature and pressure, so for a given liquid product the measured Liquident output will remain constant over a wide range of pressure or temperature.

#### Precision Volume Option:

This is the lower cost SITRANS FUH1010 meter option that uses the Liquident variable to infer only the actual liquid viscosity. This meter does NOT provide the standard volume, mass flow, liquid identification or density output available in the standard volume meter option described below. The precision volume meter is suitable for any petroleum application where actual volume required as the input to an external RTU or flow transmitter.

# Flow Measurement

## SITRANS F US Clamp-on

### System information SITRANS F US Clamp-on ultrasonic flowmeters

#### Standard Volume Option:

This Liquident variable can also be used to identify the liquid's name (gasoline, fuel oil, crude oil, etc) as well as its physical properties (specify gravity, API, viscosity and compressibility) at base conditions. With this information the meter can be configured to output a temperature and pressure compensated (standard) volume flow rate using the API 2540 and API MPMS chapter 11.2.1 methods as shown below.

#### Correction for Temperature:

Compute Thermal Expansion Coefficient ( $\alpha_b$ ):

$$\alpha_b = KO / \rho_b^2 + K1 / \rho_b$$

where: KO and K1 are constants dependent on type of liquid and  $\rho_b$  is the liquid density at base conditions

Compute temperature correction factor ( $K_T$ ):

$$K_T = \rho_b * \text{EXP}(-\alpha_b \Delta T (1 + 0.8 \alpha_b \Delta T))$$

where:  $\Delta T = (T - \text{base temperature})$

#### Correction for Pressure:

Compute Compressibility Factor (F):

$$F = \text{EXP}(A + B T + (C + D T) / \rho_b^2)$$

where: A, B, C and D are constants, and "T" is liquid temperature

Compute pressure correction factor ( $K_p$ ):

$$K_p = 1 / (1 - F (P_{\text{act}} - P_{\text{base}}) * 10^{-4})$$

**Final Volume Correction:**  $Q_{\text{std}} = Q_{\text{act}} * K_t * K_p$

Available outputs from this meter include: API, Density, Mass Flowrate, Standard Volume Flowrate and Liquid Identification.

#### Interface Detection Option:

This meter option is designed to provide all the Non-Flow capabilities of a DV meter, making it an ideal non-intrusive alternative to a densitometer, interface detector or pig detector. Be aware that this meter does NOT measure flow rate.

#### SITRANS FUT1010 Liquid and gas flowmeters

The SITRANS FUT1010 is available in two different configurations; a version for liquid hydrocarbon applications and a version for precise gas measurement. Both versions are offered in pipe sizes ranging from 4 inch to 24 inch (DN100 to DN 600) with flange ratings of ANSI Class gas.

#### General Installation Guidelines for transit time Clamp-On Sensor

- Minimum measuring range: 0 to  $\pm 0.3$  m/s velocity (see meter accuracy graph below for more detail)
- Maximum measuring range: 0 to  $\pm 12$  m/s ( $\pm 30$  m/s for high precision sensors). Final flow range determination requires application review

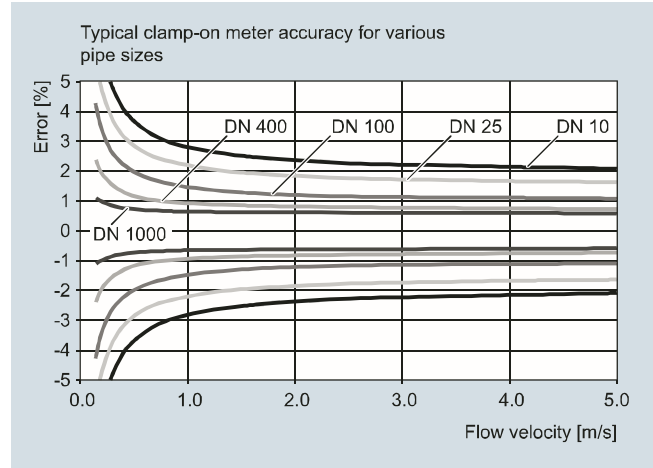

- Pipe must be completely full within the sensor installation volume for accurate flow measurement
- Typical MINIMUM straight pipe requirements are: 10 Diameters upstream/5 Diameters downstream. Additional straight run is required for double out-of-plane elbows and partially open valves. A minimum of 20 upstream diameters is recommended for clamp-on gas systems
- Sensors should be installed at least 20° off vertical for horizontal pipes. This reduces the chance of beam interference from gas buildup at the top of the pipe
- Operation inside the Reynolds transition region, between  $1000 < Re < 5000$  should be avoided for best accuracy
- Submersible and direct burial installations can be accommodated. Consult sales representative for details
- Ultrasonic coupling compound is provided with all sensor orders. Insure that a permanent coupling compound is used for long term installations
- Refer to the "Sensor type selection guide" to insure proper application of the equipment

# Flow Measurement SITRANS F US Clamp-on

System information SITRANS F US  
Clamp-on ultrasonic flowmeters

## Dimensional drawings

### SITRANS FUS1010, FUE1010, FUH1010, FUT1010 and FUG1010 IP65 (NEMA 4X) wall mount enclosure

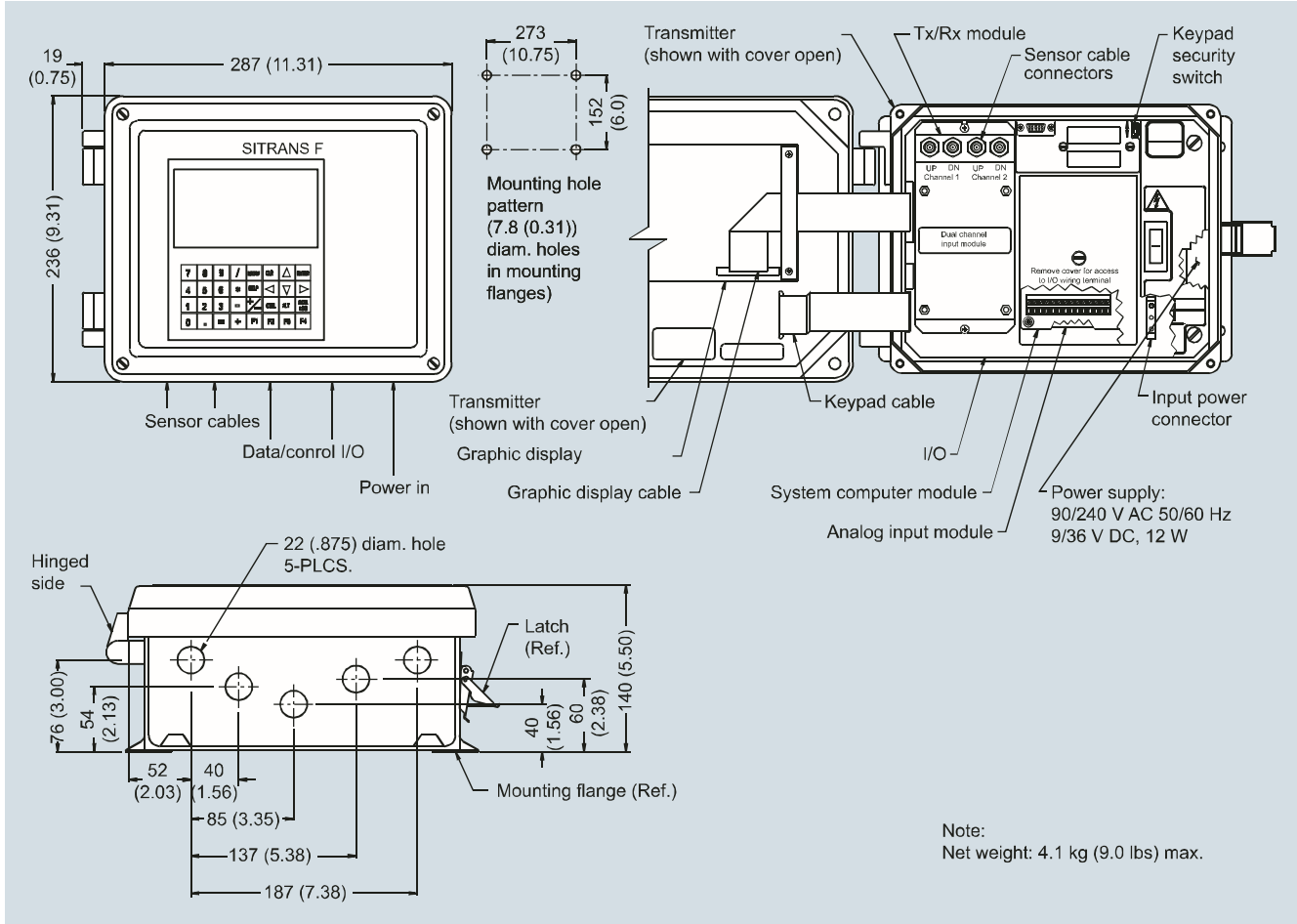

Dimensions in mm (inch)

### SITRANS FUS1010, FUH1010 and FUG1010 IP65 (NEMA 7) compact explosionproof enclosure

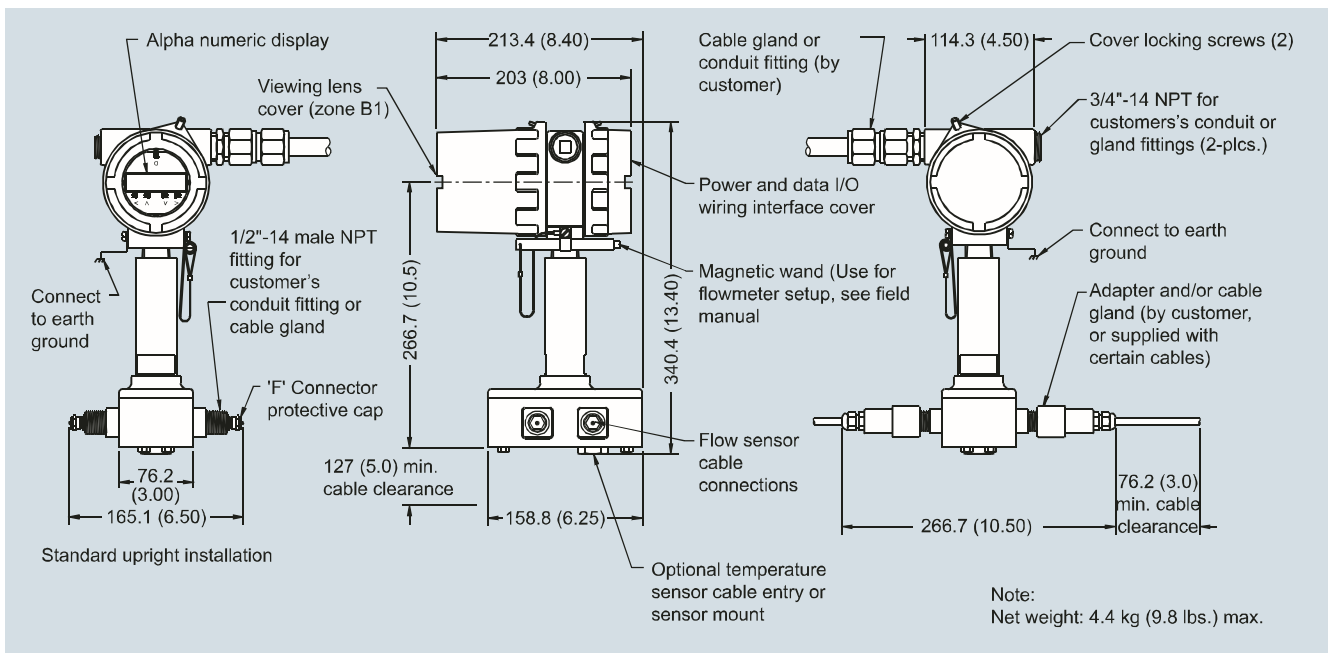

# Flow Measurement SITRANS F US Clamp-on

**System information SITRANS F US  
Clamp-on ultrasonic flowmeters**

**SITRANS FUS1010, FUH1010, FUT1010 and FUG1010 IP66 (NEMA 7) wall mount explosionproof enclosure**

3

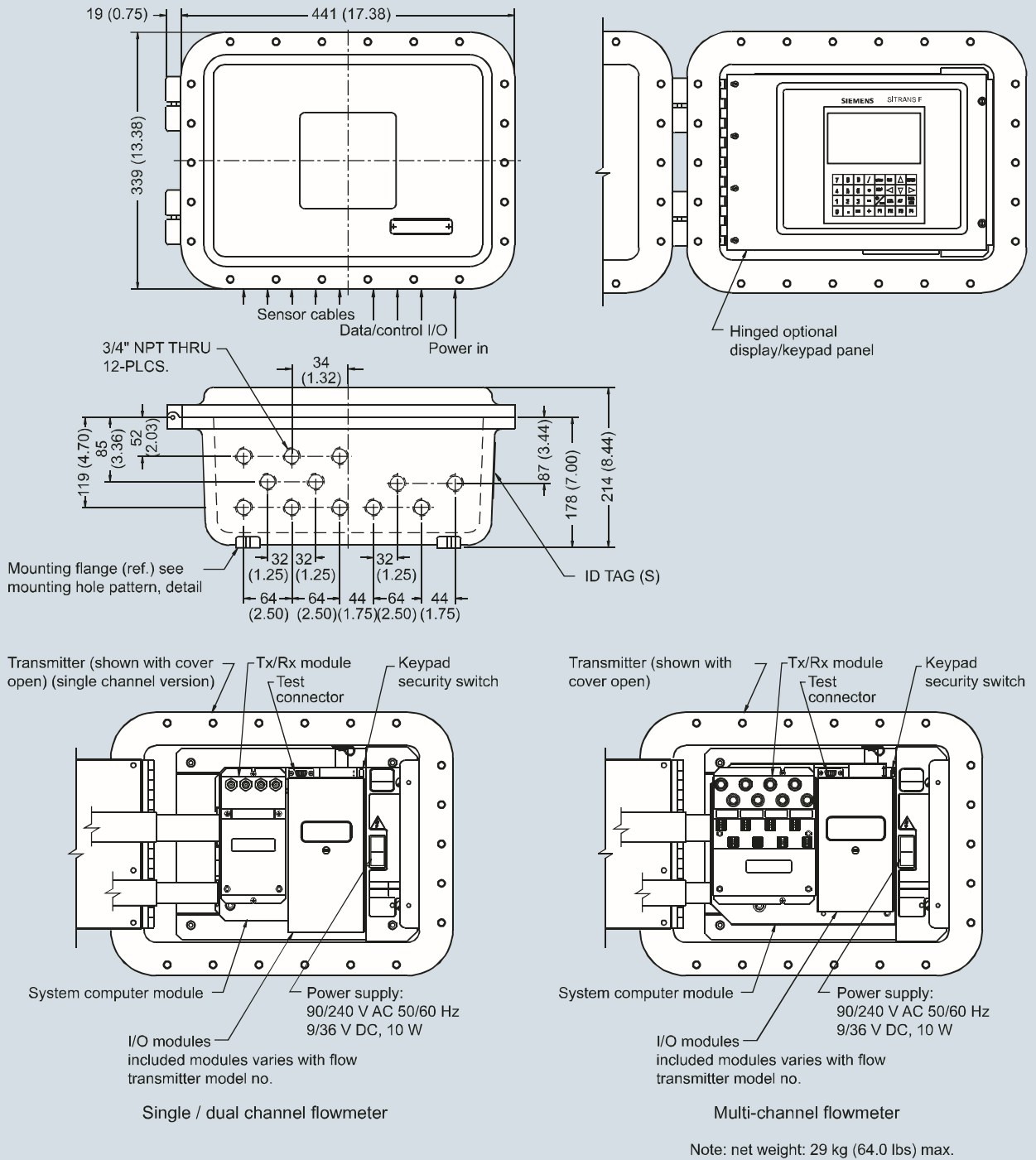

# Flow Measurement SITRANS F US Clamp-on

## System information SITRANS F US Clamp-on ultrasonic flowmeters

### SITRANS FUP1010 IP67 Weatherproof impact resistant enclosure

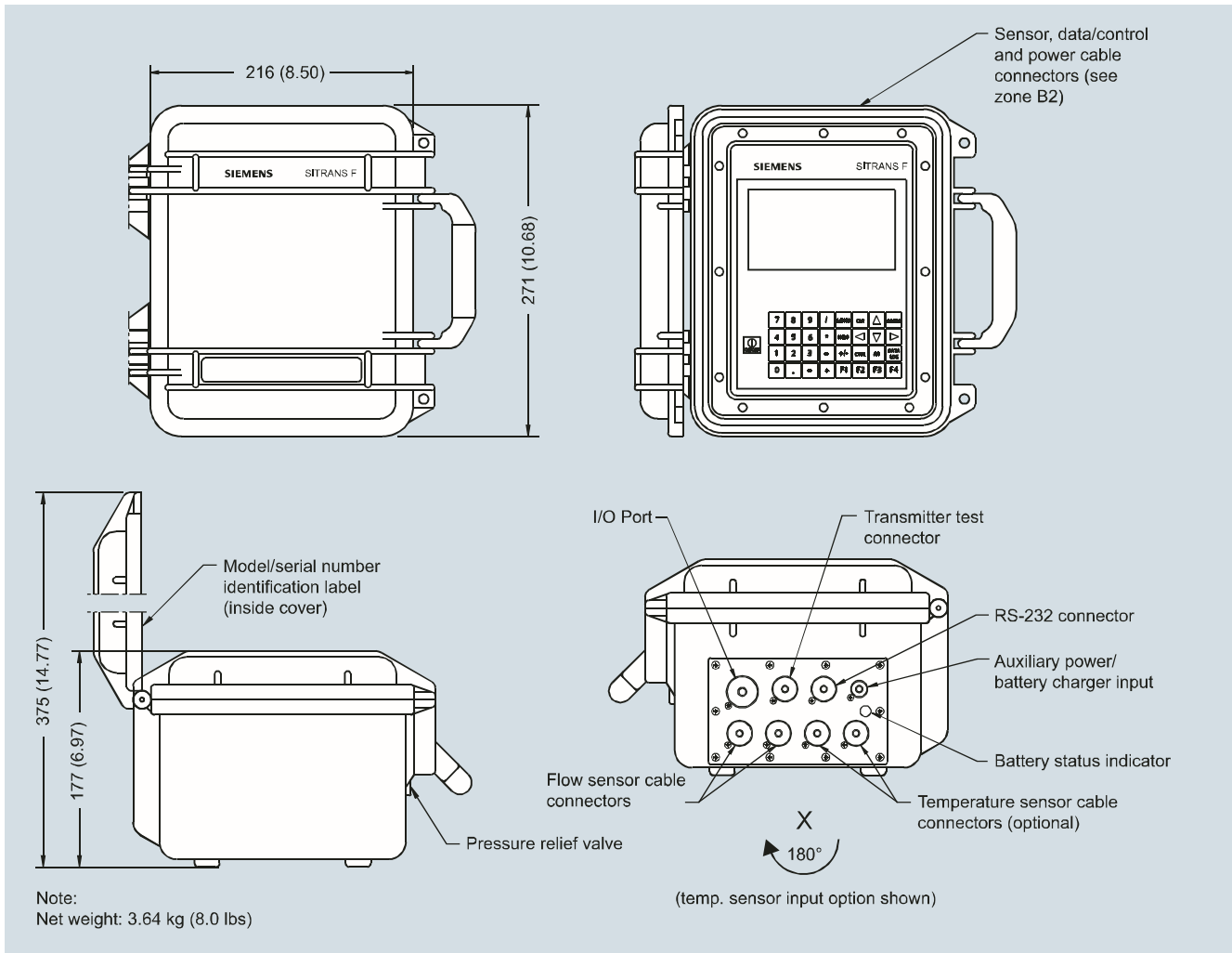

Dimensions in mm (inch)

# Flow Measurement SITRANS F US Clamp-on

System information SITRANS F US  
Clamp-on ultrasonic flowmeters

## SITRANS FUE1010 IP40 (NEMA 1) Portable impact resistant enclosure

3

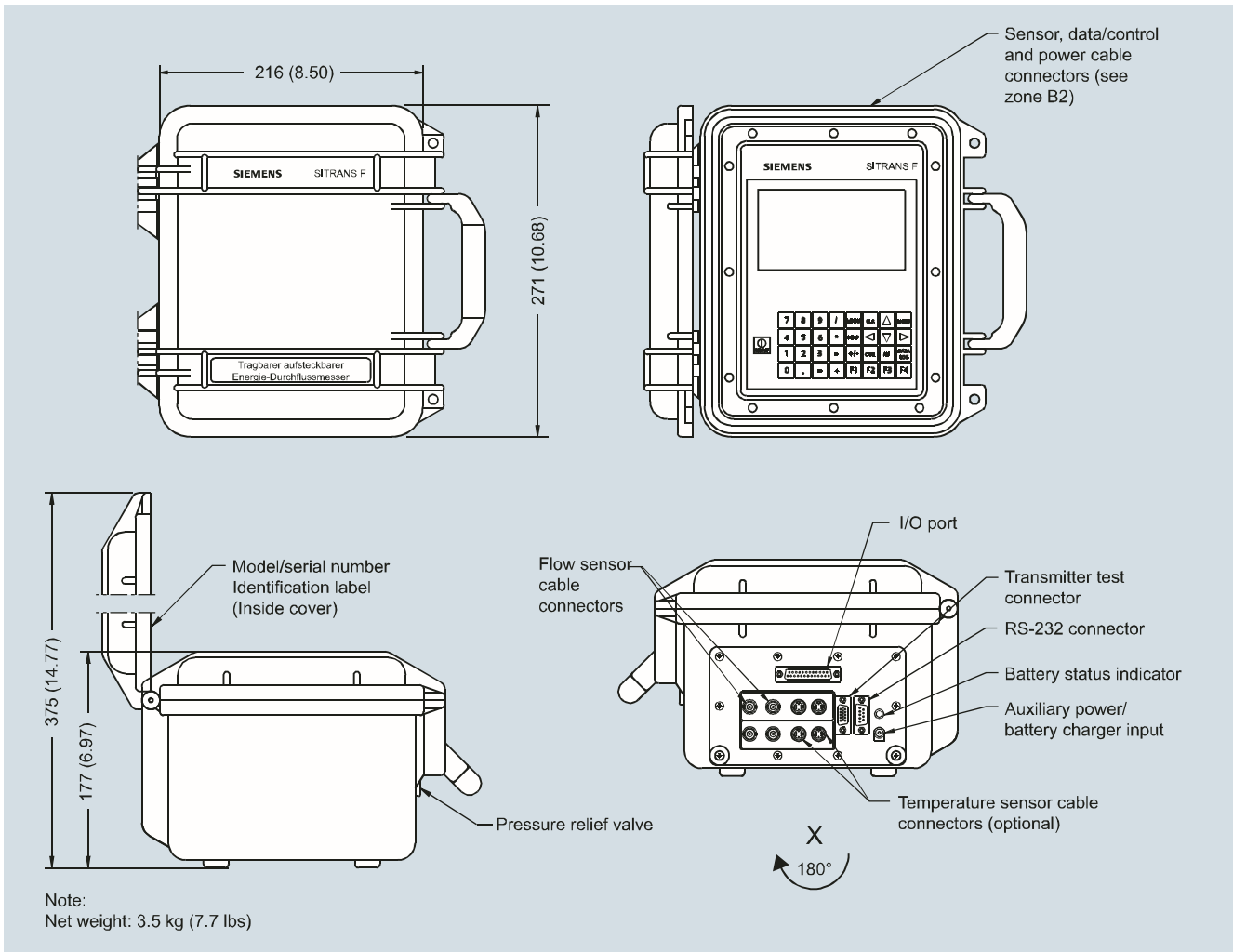

Dimensions in mm (inch)

# Flow Measurement SITRANS F US Clamp-on

System information SITRANS F US  
Clamp-on ultrasonic flowmeters

## SITRANS FST020 IP65 (NEMA 4X) wall mount enclosure

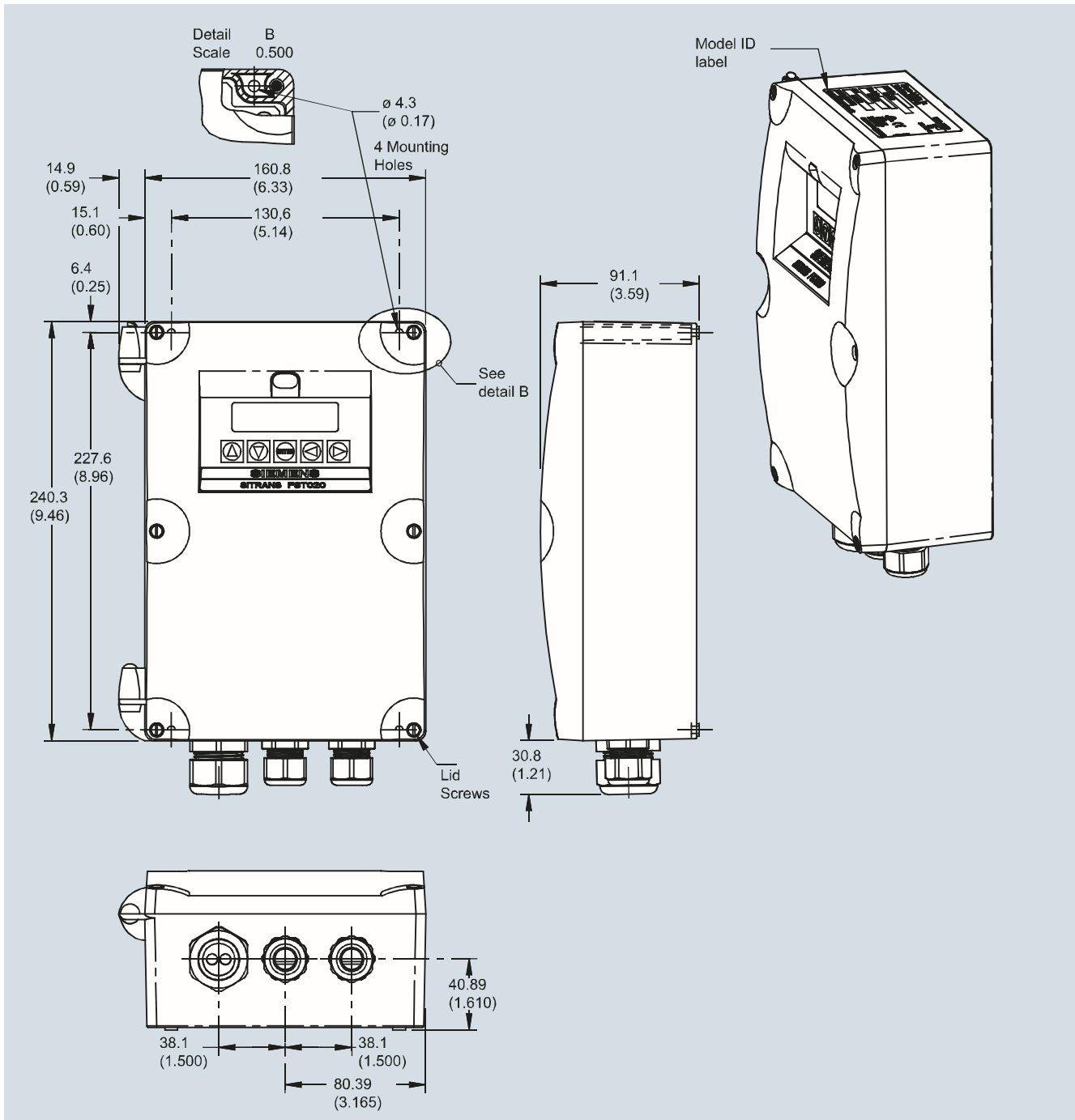

Dimensions in mm (inch)



# Flow Measurement

## SITRANS F US Clamp-on

### Thickness gauge

#### Overview



The thickness gauge is used to measure the wall thickness of the pipe that a clamp-on ultrasonic flowmeter is installed on. The wall thickness value is a vital factor in the flow computation model and a prerequisite for precise clamp-on ultrasonic flow measurement. When measuring any pipe wall thickness the thickness gauge can also be used as a stand-alone tool used to measure the wall thickness of any metallic or non-metallic pipe materials capable of acting as an ultrasonic wave conductor.

#### Benefits

The thickness gauge is an indispensable tool in accurate clamp-on ultrasonic flow measurement. For a flowmeter to measure correctly it needs to know the exact wall thickness of the pipe it is measuring on. Since even the smallest miscalculation can have a major effect on the flow reading, the pipe thickness gauge has to be extremely precise. This is why the standard probe operates at a 5 MHz frequency making it capable of measuring pipe thickness ranging from 0.1 to 200 mm (0.03" to 7.9") with a very high resolution of up to 0.1 mm (0.004").

#### Application

The thickness gauge can be used in any field application where there is a need for flow measurement.

#### Design

The hand-held micro-processor controlled gauge is designed to measure the thickness of various metallic or non-metallic pipe. Such materials include steel, aluminum, titanium, plastics and ceramics. Measurement results are shown in either inches or millimeter; only a simple pre-calibration to a known thickness or sound velocity is required. The simple-to-read 4-digit LCD display featuring a basic user friendly menu is easily navigable with only three conveniently located push buttons. The lightweight computing unit weighs a mere 150 g (5.3 oz) making it ideal for quick and easy on-site pipe wall thickness measurement and with two AAA alkaline batteries trouble-free operation is ensured for 250 hours.

#### Function

The thickness gauge measurement is based on the transit time ultrasonic wave propagation principle: a high frequency ultrasonic beam is transmitted into the pipe being measured through a probe acting as a sender and receiver. When the probe subsequently retrieves that same signal, an internal counter calculates the time taken for the signals to be sent and received through the pipe. This value is used to evaluate the speed of sound through the pipe and consequently, the thickness of the pipe wall.

#### Technical specifications

Display type	4-digit LCD
Display resolution	0.1 mm (0.004")
Measurement units	Metric and imperial
Sound velocity range	1 000 ... 9 999 m/s (3 280 ... 32 805 ft/s)
Operating temperature	-10 ... +50 °C (14 ... 122 °F)
Probe/pipe temperature	70 °C (158 °F)
Update rate	4 Hz
Frequency	5 MHz
Power source	2 x 1.5 V AAA dry cells
Power consumption	Working current is less than 3 mA
Battery life	Approx. 250 h on a set of batteries
Dimensions (W x H x D)	61 x 108 x 28 mm (2.4 x 4.3 x 1.1")
Weight	150 g (5.3 oz)

#### Selection and Ordering data

Selection and Ordering data	Article No.
<b>Thickness gauge</b>	<b>7ME3951-0TG20</b>