

Pressure Measurement

Transmitters for basic requirements

SITRANS P250 for differential pressure

1

Overview



The SITRANS P250 transmitter measures the differential pressure of liquids and gases.

Benefits

- High measuring accuracy
- Sturdy stainless steel enclosure
- For aggressive and non-aggressive media
- For the measurement of the differential pressure of liquids and gases
- Temperature-compensated measuring cell
- Compact design

Application

The SITRANS P250 transmitter for differential pressure is primarily used in the following industries:

- Chemical industry
- Heating, ventilation and air conditioning technology
- Food industry
- Mechanical engineering
- Shipbuilding
- Water supply

Design

Main components:

- Stainless steel enclosure with piezo-resistive ceramic measuring cell (temperature-compensated) and electronics module
- Process connection made of stainless steel in diverse designs (see Selection and Ordering data)
- Electrical connection through connectors acc. to EN 175301-803-A and round connectors M12, as well as with permanently fixed cable

Function

The pressure transmitter measures the differential pressure of liquids and gases.

Mode of operation

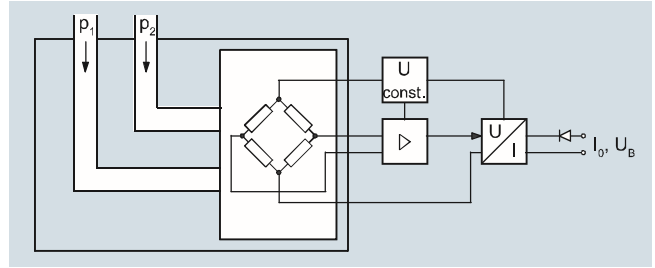

SITRANS P250 pressure transmitter, function diagram

The piezo-resistive measuring cell (ceramic membrane) has a Wheatstone bridge circuit, on which the operating pressure P1 and P2 of the media acts at both ends.

The voltage output from the measuring cell is converted by an amplifier into an output current of 4 to 20 mA or an output voltage of 0 to 5 or 10 V DC.

The output current and voltage are linearly proportional to the input pressure.

Technical specifications

SITRANS P250 differential pressure transmitter	
Application	
Differential pressure transmitter	Liquids and neutral gases
Mode of operation	
Measuring principle	Piezo-resistive measuring cell (ceramic diaphragm)
Input	
Measured variable	Differential pressure
Measuring range	0 ... 0.1 to 0 ... 25 bar (0 ... 1.45 to 0 ... 363 psi)
Operating pressure	≤ 25 bar at a differential pressure range > 6 bar ≤ 50 bar at a differential pressure range > 10 bar
Burst pressure	1.5 x operating pressure
Output	
Output signal	
• Current output signal	4 ... 20 mA
• Voltage output signal	0 ... 5 V DC and 0 ... 10 V DC
Load	
• 3-wire	> 10 kΩ
• 2-wire	≤ (U _H - 11 V) / 0.02 A
Measuring accuracy	
Error in measurement at limit setting incl. hysteresis and reproducibility	≤ 1 % of typical full-scale value, see "Measuring range" table
Long-term stability acc. to IEC 60770	≤ 0.5 % of full-scale value/year
Influence of ambient temperature	
• Start of scale	≤ 0.6 % / 10 K of full-scale value (≤ 1.2 % / 10K for measuring cell 0 ... 0.1 bar (1.45 psi))
• Full-scale value	≤ 0.22 % / 10 K of full-scale value (≤ 0.37 % / 10K for measuring cell 0 ... 0.1 bar (1.45 psi))
Dynamic behavior	Suitable for static and dynamic measurements
Step response time T ₉₉	< 5 ms
Load variation	< 50 Hz

Pressure Measurement

Transmitters for basic requirements

SITRANS P250
 for differential pressure

1

Rated conditions	
Ambient conditions	
• Temperature of medium	-15 ... +85 °C (5 ... 185 °F)
• Ambient temperature	-15 ... +85 °C (5 ... 185 °F)
• Storage temperature	-40 ... +85 °C (-40 ... +185 °F)
Degree of protection acc. to EN 60529	IP65
Mounting position	Any
Mounting	Mounting bracket, included in delivery
Design	
Weight	Approx. 430 g (approx. 0.95 lb)
Enclosure material	Stainless steel 1.4305/AISI 303
Electrical connection	<ul style="list-style-type: none"> • Plug EN 175301-803-A • Circular plug EN 60130-9 • Cable 1.5 m
Process connection	<ul style="list-style-type: none"> • Hose sleeve Ø 4 mm/6 mm • Pipe union Ø 6 mm/8 mm • Male thread 7/16-20 UNF, G1/8" • Female thread 1/8-27 NPT • (Standard), G1/8"
Wetted parts materials	
• Process connection	Stainless steel 1.4305/AISI 303, brass nickel-plated
• Diaphragm	Ceramic Al ₂ O ₃ (96 %)
• Sealing material	FPM (standard), EPDM, NBR, MVQ, CR
Power supply U _H	
Terminal voltage on pressure transmitter	
• 2-wire, 4 ... 20 mA	11 ... 33 V DC
• 3-wire, 0 ... 5 V DC	11 ... 33 V DC/24 V AC ±15 %
• 3-wire, 0 ... 10 V DC	18 ... 33 V DC/24 V AC ±15 %
Current consumption at nominal pressure	
• 2-wire	< 20 mA
• 3-wire	< 5 mA
Protection against polarity reversal	Protected against short-circuit and polarity reversal. Each connection against the other with max. supply voltage.
Certificates and approvals	
Approval	CE conformity

Measuring range		Max. perm. operating pressure (on either side)	Burst pressure	Max. perm. operating pressure (on one side)	Accuracy
[bar]	[inH ₂ O]				
0 ... 0.1	0 ... 40.18	25 bar (363 psi)	37.5 bar (544 psi)	0.6 bar (241 inH ₂ O)	≤ 1.0 %
0 ... 0.2	0 ... 80.37	25 bar (363 psi)	37.5 bar (544 psi)	0.6 bar (241 inH ₂ O)	≤ 0.8 %
0 ... 0.25	0 ... 100.46	25 bar (363 psi)	37.5 bar (544 psi)	0.6 bar (241 inH ₂ O)	≤ 0.5 %
0 ... 0.3	0 ... 120.56	25 bar (363 psi)	37.5 bar (544 psi)	0.6 bar (241 inH ₂ O)	≤ 0.5 %
0 ... 0.4	0 ... 160.74	25 bar (363 psi)	37.5 bar (544 psi)	1.2 bar (482 inH ₂ O)	≤ 0.8 %
0 ... 0.5	0 ... 200.9	25 bar (363 psi)	37.5 bar (544 psi)	1.2 bar (482 inH ₂ O)	≤ 0.5 %
0 ... 0.6	0 ... 241.0	25 bar (363 psi)	37.5 bar (544 psi)	1.2 bar (482 inH ₂ O)	≤ 0.5 %
0 ... 1.0	0 ... 402.0	25 bar (363 psi)	37.5 bar (544 psi)	2 bar (804 inH ₂ O)	≤ 0.5 %
0 ... 1.6	0 ... 643.0	25 bar (363 psi)	37.5 bar (544 psi)	3.2 bar (1286 inH ₂ O)	≤ 0.5 %
0 ... 2.5	0 ... 1005	25 bar (363 psi)	37.5 bar (544 psi)	5 bar (2009 inH ₂ O)	≤ 0.5 %
0 ... 4	0 ... 1607	25 bar (363 psi)	37.5 bar (544 psi)	8 bar (3215 inH ₂ O)	≤ 0.5 %
0 ... 6	0 ... 2411	25 bar (363 psi)	37.5 bar (544 psi)	12 bar (4822 inH ₂ O)	≤ 0.5 %
0 ... 10	0 ... 4019	50 bar (725 psi)	75 bar (1088 psi)	20 bar (8037 inH ₂ O)	≤ 0.5 %
0 ... 16	0 ... 6430	50 bar (725 psi)	75 bar (1088 psi)	32 bar (464 psi)	≤ 0.5 %
0 ... 25	0 ... 10046	50 bar (725 psi)	75 bar (1088 psi)	50 bar (725 psi)	≤ 0.5 %

Schematics

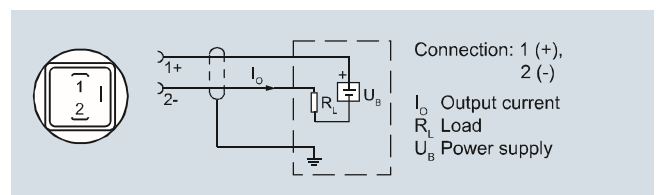

Connection with current output 4 ... 20 mA and plug to EN 175301-803-A

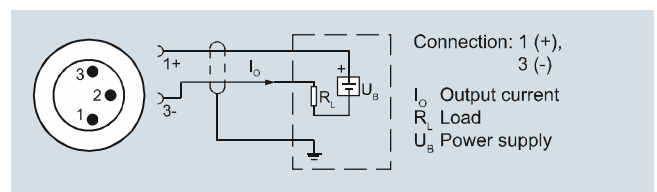

Connection with current output 4 ... 20 mA and round connector

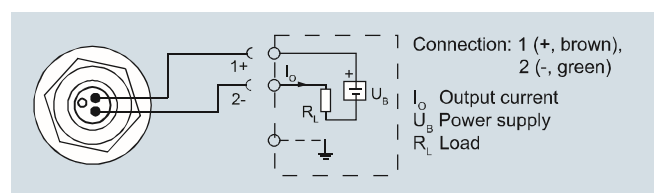

Connection with current output 4 ... 20 mA and permanently fixed cable

Pressure Measurement

Transmitters for basic requirements

SITRANS P250 for differential pressure

1

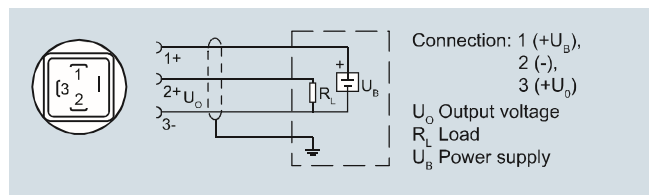

Connection with voltage output 0 ... 5 V DC (0 ... 10 V DC) and plug to EN 175301-803-A

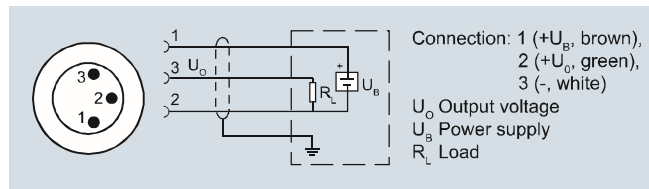

Connection with voltage output 0 ... 5 V DC (0 ... 10 V DC) and round connector

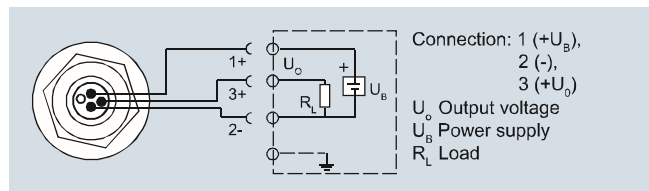

Connection with voltage output 0 ... 5 V DC (0 ... 10 V DC) and permanently fixed cable

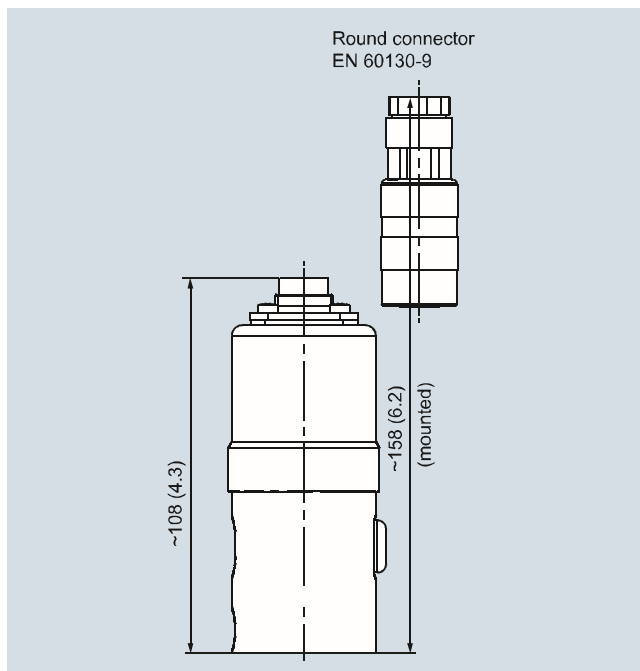

SITRANS P250 differential pressure transmitter with round connector to EN 60130-9, dimensions in mm (inch)

Dimensional drawings

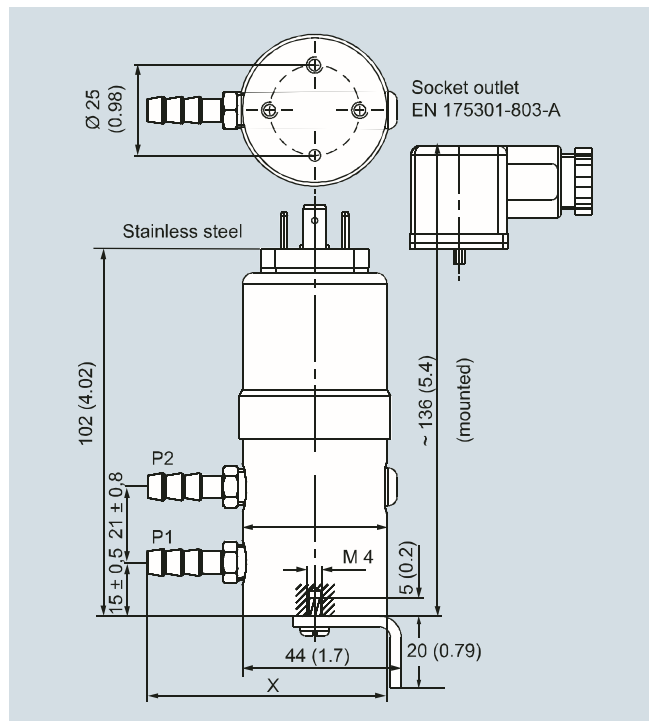

SITRANS P250 differential pressure transmitter with socket outlet to EN 175301-803-A, dimensions in mm (inch)

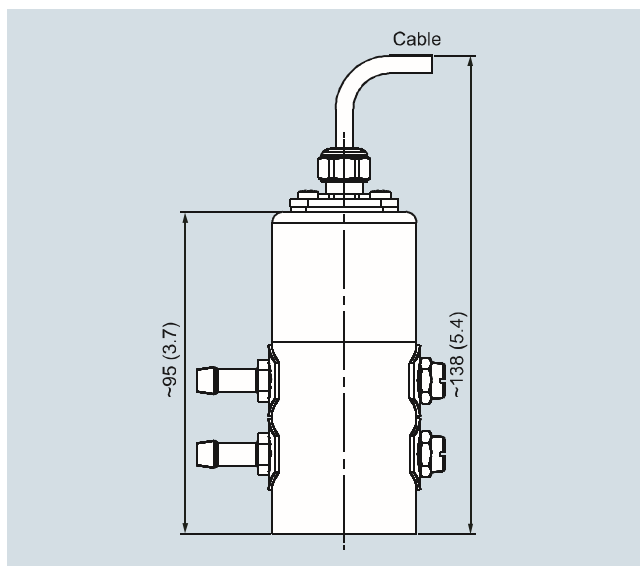

SITRANS P250 differential pressure transmitter with cable, dimensions in mm (inch)

Pressure Measurement

Transmitters for basic requirements

SITRANS P250
for differential pressure

1

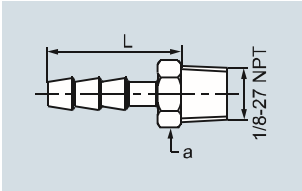
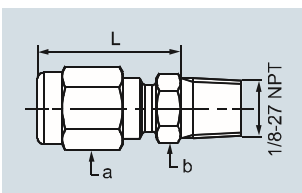
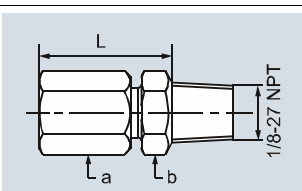
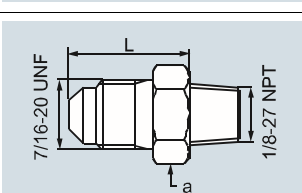
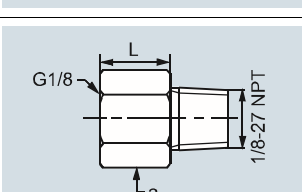
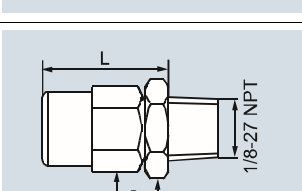
Process connections	Ø	Width across flats		L		X	
		[mm]	[inch]	[mm]	[inch]	[mm]	[inch]
 <p>Hose connection for hose (brass nickel-plated)</p>	4	0.16	a = 10	20	0.79	61	2.40
	6	0.24	a = 10	25	0.99	66	2.60
 <p>Pipe union with screw-in nipple for outer pipe (brass nickel-plated)</p>	6	0.24	a = 10 b = 12	24	0.95	65	2.56
	8	0.32	a = 12 b = 14	25	0.99	66	2.60
 <p>Pipe union with screw-in nipple for outer pipe (stainless steel 1.4305/AISI 303)</p>	6	0.24	a = 10 b = 12	24	0.95	65	2.56
	8	0.32	a = 12 b = 14	26	1	67	2.64
 <p>Male thread 7/16-20 UNF (brass nickel-plated)</p>	-	-	a = 14	18	0.71	59	2.32
 <p>Female thread G1/8 (stainless steel 1.4305/AISI 303)</p>	-	-	a = 14	12	0.47	53	2
 <p>Male thread G1/8 (brass nickel-plated)</p>	-	-	a = 10 b = 12	20	0.79	61	2.40

Pressure Measurement

Transmitters for basic requirements

SITRANS P250 for differential pressure

1

Selection and Ordering data	Article No.	Order code
SITRANS P 250 pressure transmitter for differential pressure Accuracy ≤ 1 %, wetted parts ceramic/stainless steel 1.4301, scope of delivery: transmitter, mounting bracket and instruction manual, without explosion protection	7MF1641 -	0 - 0
Measuring range		
0 ... 0.1 bar (0 ... 40.19 inH ₂ O) ▶◆		3AA
0 ... 0.2 bar (0 ... 80.37 inH ₂ O) ▶◆		3AC
0 ... 0.25 bar (0 ... 100.46 inH ₂ O) ▶◆		3AD
0 ... 0.3 bar (0 ... 120.56 inH ₂ O) ▶◆		3AE
0 ... 0.4 bar (0 ... 160.74 inH ₂ O) ▶◆		3AF
0 ... 0.5 bar (0 ... 201.0 inH ₂ O) ▶◆		3AG
0 ... 0.6 bar (0 ... 241.0 inH ₂ O) ▶◆		3AH
0 ... 1.0 bar (0 ... 402.0 inH ₂ O) ▶◆		3BA
0 ... 1.6 bar (0 ... 643.0 inH ₂ O) ▶◆		3BB
0 ... 2.5 bar (0 ... 1005.0 inH ₂ O) ▶◆		3BD
0 ... 4.0 bar (0 ... 1607.0 inH ₂ O) ▶◆		3BE
0 ... 6.0 bar (0 ... 2411.0 inH ₂ O) ▶◆		3BG
0 ... 10.0 bar (0 ... 4019.0 inH ₂ O) ▶◆		3CA
0 ... 16.0 bar (0 ... 6430.0 inH ₂ O) ▶◆		3CB
0 ... 25.0 bar (0 ... 10046 inH ₂ O) ▶◆		3CD
Other version, add Order code and plain text (Note: smallest possible span 100 mbar (40.19 inH ₂ O))		
Output signal		
4 ... 20 mA ▶◆		0
0 ... 5 V DC		1
0 ... 10 V DC		2
Electrical connection		
Plug acc. to EN 175 301-803-A (suitable coupling included in scope of delivery) ▶◆		1
Round connector acc. to EN 60139-9		2
Cable 1.5 m with cable gland		3
Process connection		
Without connections, female thread 1/8-27 NPT ▶◆		A
Hose connection		
• Brass nickel-plated, for hose Ø 4 mm		B
• Brass nickel-plated, for hose Ø 6 mm		C
• PVDF, for hose Ø 6 mm		D
Pipe union		
• Brass nickel-plated, for pipe Ø 6 mm		E
• Stainless steel 1.4304, for pipe Ø 6 mm		F
• Brass nickel-plated, for pipe Ø 8 mm		G
• Stainless steel 1.4304, for pipe Ø 8 mm		H
Male thread, 7/16-20 UNF (Brass nickel-plated)		L
Adapter		
• Inner, G1/8 (stainless steel), for pipe Ø 6 mm		M
• Outer, G1/8 (Brass nickel-plated), with union nut, for pipe Ø 6 mm		N
Sealing material		
Fluoro rubber (Viton/FPM) ▶◆		A
Ethylene propylene diene monomer rubber (EPDM)		B
Nitrile butadiene rubber (NBR)		C
Silicone rubber (MVQ)		D
Neoprene (CR)		E
Further designs	Order code	
Please add '-Z' to Article No. and specify Order code(s).		
Quality inspection certificate (factory calibration) to IEC 60770-2	C11	

▶ Available ex stock

◆ We can offer shorter delivery times for configurations designated with the Quick Ship Symbol ◆. For details see page 9/5 in the appendix.