

Pressure Measurement Transmitters with WirelessHART

SITRANS P280
for gauge and absolute pressure

1

Overview



SITRANS P280 for flexible and cost-effective applications in pressure monitoring

- Supports the WirelessHART standard (HART V 7.1)
- Very high security level for wireless data transmission
- Built-in local user interface (LUI) with 3-button operation
- Optimum display and readability using graphical display (104 x 80 pixels) with integrated backlight
- Stand-by (deep sleep phase) can be activated and deactivated device with push of a button
- Battery power supply
- Battery service live up to 5 years
- Extend battery service life with HART modem interface which can be shut off
- Optimized power consumption through new design, and increase in battery service life.
- Simple configuration thanks to SIMATIC PDM
- Device meets IP65 degree of protection
- Can be used for absolute and gauge pressure measurements

Benefits

The SITRANS P280 is a pressure transmitter that features Wireless HART as the standard communication interface.

Also available is a wired interface to connect a HART modem:

- Flexible pressure measurements
- Save costs on wiring for difficult installation conditions. Wireless technology offers cost advantages in cases where extensive wiring cost would normally apply.
- It enables additional hitherto unfeasible measuring points, particularly for monitoring purposes.
- Easy installation on moveable equipment
- Enables cost-effective temporary measurements, for example for process optimizations.
- Optimum solution in addition to wired communication and new possibilities for system solutions in process automation

Application

The SITRANS P280 is a WirelessHART field device for measuring absolute and gauge pressure.

The measuring ranges for absolute and gauge pressure measurements are 0 to 1.6, 10, 50, 200 and 320 bar (0 to 23, 145, 725, 2900 and 4641 psi).

The sensor is integrated into the transmitter housing.

On the wireless communication side, the transmitter supports the WirelessHART standard. A HART modem can be connected to the transmitter particularly for initial commissioning, alternatively the device can be commissioned comfortably by means of the local pushbuttons w/o any additional handset devices.

It can be used in all industries and applications in non-explosive areas.

Design

The SITRANS P280 has a robust aluminum enclosure and is suitable for outside use. It conforms with the IP65 safety class.

The operating temperature range is -40 to +80 °C (-40 to +176 °F). Power supply is provided through an integrated battery, which is available as an accessory. The device is only approved for operation with this battery.

The aerial features a rotatable joint which can be used for directional alignment. Wireless signals can thus be optimally received and transmitted.

A special highlight is the option for direct operation on the device. The operating strategy used in this case seamlessly integrates into the strategy of all new Siemens field devices.

Using the device's control buttons, it is easy to turn the HART modem interface of the device on and off. The device can be put to passive status and reactivated at any time. This helps to extend the service life of the battery.

The SITRANS P280 transmitter features a ceramic measuring cell for gauge and absolute pressure measurements.

Function

The SITRANS P280 can join to a WirelessHART network. It can be parameterized and operated through this network. Measured process values are transported via the network to the SIEMENS IE/WSN-PA link.

Field device data received by the IE/WSN-PA LINK is transmitted to the connected systems, for example the process control system SIMATIC PCS 7. For an introduction of WirelessHART, please see the FI 01 catalogue, section 8 or <http://www.siemens.com/wirelesshart>.

Detailed information on IE/WSN-PA can be found in the FI 01 catalogue, section 8 or <http://www.siemens.com/wirelesshart>.

Pressure Measurement Transmitters with WirelessHART

SITRANS P280 for gauge and absolute pressure

1

Integration

Connecting to SIMATIC PCS 7

The integration of field devices in SIMATIC PCS 7 and other process control systems can now be done seamlessly and cost-effectively with wireless technology, especially in situations where high wiring costs may be expected. Of particular interest are measuring points which are to be added and for which no MSR wiring is available.

Where larger distances between the IW/WSN-PA LINK and control systems need to be overcome, this connection can also be implemented on a wireless and cost-effective basis using the products of the SCALANCE W family.

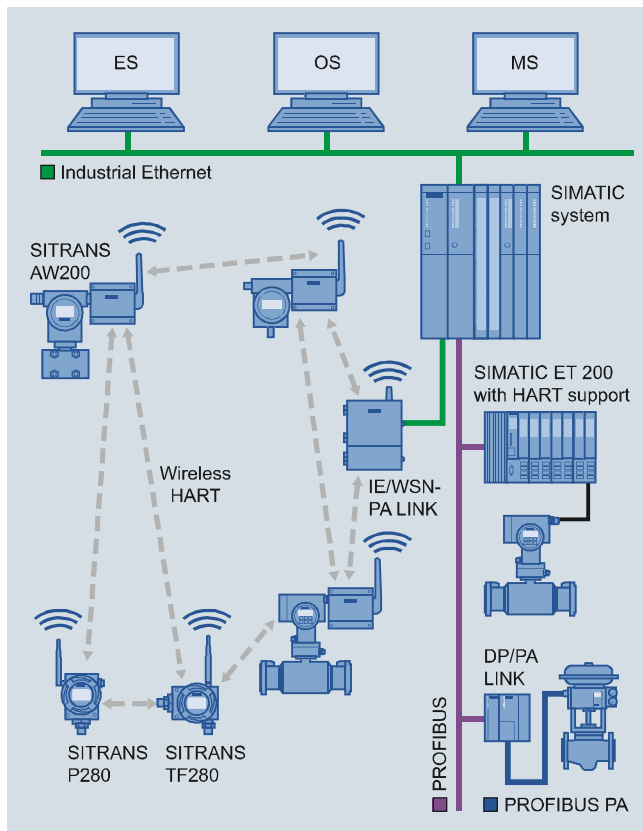

Integration of a meshed network in SIMATIC PCS 7

Configuration

Configuration of the SITRANS P280 may be carried out as follows:

- Initial commissioning for the SITRANS P280 with SIMATIC PDM is generally carried out via a HART modem or the integrated local user interface, since the network ID and join key must be set up on the device before it can be accepted and integrated into the WirelessHART network.
- Once it is integrated into the network, the device can be conveniently operated with the WirelessHART network, the onsite HART modem or via the local user interface.
- Siemens WirelessHART devices operate with optimum coexistence to SCALANCE W family products.

Technical specifications

SITRANS P280 WirelessHART pressure transmitter

Mode of operation	
Measuring principle	piezo-resistive
Measured variable	Gauge and absolute pressure
Gauge pressure input	
Measuring range	Overload limit/Bursting pressure
0 ... 1.6 bar (0 ... 23 psi)	4 bar (58 psi)
0 ... 10 bar (0 ... 145 psi)	20 bar (290 psi)
0 ... 50 bar (0 ... 725 psi)	100 bar (1450 psi)
0 ... 200 bar (0 ... 2900 psi)	400 bar (5801 psi)
0 ... 320 bar (0 ... 4641 psi)	640 bar (9282 psi)
Units	mbar, bar, m ₄ H ₂ O, i ₄ H ₂ O, atm, Torr, gcm ² , kgcm ² , Pa, kPa, MPa, psi, mmHG, mmH ₂ O, ftH ₂ O, inHG, inH ₂ O
Absolute pressure input	
Measuring range	Overload limit/Bursting pressure
0 ... 1.6 bar a (0 ... 23 psia)	4 bar a (58 psia)
0 ... 10 bar a (0 ... 145 psia)	20 bar a (290 psia)
0 ... 50 bar a (0 ... 725 psia)	100 bar a (1450 psia)
0 ... 200 bar a (0 ... 2900 psia)	400 bar a (5801 psia)
0 ... 320 bar a (0 ... 4641 psia)	640 bar a (9282 psia)
Units	mbar, bar, m ₄ H ₂ O, i ₄ H ₂ O, atm, Torr, gcm ² , kgcm ² , Pa, kPa, MPa, psi, mmHG, mmH ₂ O, ftH ₂ O, inHG, inH ₂ O
Output	
Output signal	2.4 GHz Wireless signal with TSMP (Time Synchronized Mesh Protocol)
Measuring accuracy	
Error in measurement at limit setting incl. hysteresis and reproducibility	typ. 0.17 % of sensor's span max. 0.25 % of sensor's span
Long-term stability	max. ± 0.25 % of sensor/year span
Influence of ambient temperature	typ. 0.07 %/10K, max. 0.2 %/10 K of sensor's span
Rated conditions	
Ambient conditions	
• Ambient temperature	-40 ... +80 °C (-40 ... +176 °F) (in ambient temperatures below -20 °C (-4 °F) and above +70 °C (158 °F), readability of the display is limited.)
• Storage temperature	-40 ... +85 °C (-40 ... +185 °F)
• Relative humidity	< 95 %
Climatic class	4K4H in accordance with EN 60721-3-4 (stationary use at locations not protected against weather)
Degree of protection	IP65/NEMA 4
Allowable media temperature	-40 ... 85 °C (-40 ... +185 °F)

Pressure Measurement Transmitters with WirelessHART

SITRANS P280

for gauge and absolute pressure

1

Design	
Enclosure material	low-copper die-cast aluminum, AC-AISI12(Fe)
Shock resistance	in accordance with DIN EN 60068-2-29 / 03.95
Resistance to vibration	in accordance with DIN EN 60068-2-6/ 12.07
Weight	
• without battery	1.5 kg (3.31 lb)
• With battery	1.6 kg (3.53 lb)
Dimensions (W x H x D)	See Dimensional drawing
Process connection	<ul style="list-style-type: none"> • G½B male thread as per EN837-1 • ½-14 NPT
Sensor break	Is recognized
Displays and controls	
Display (with illumination)	
• Size of display	104 x 80 pixels
• Number of digits	adjustable
• Number of spaces after comma	adjustable
Setting options	<ul style="list-style-type: none"> • on site with 3 buttons • with SIMATIC PDM or HART-Communicator
Power supply	
Battery	3.6 V DC
Communication	
Radio	WirelessHART V7.1 conforming
Transmission frequency band	2.4 GHz (ISM-Band)
Transmission range under reference conditions	<p>Up to 250 m (line of sight) in outside areas</p> <p>Up to 50 m (greatly dependent on obstacles) in inside areas</p>
Communication interfaces	<ul style="list-style-type: none"> • HART communication with HART modem • WirelessHART
Certificates and approvals	
Wireless communication approvals	R&TTE, FCC
General Product Safety	CSA _{US/C} , CE, UL
Classification according to pressure equipment directive (PED 97/23/EC)	<p>Gases: Fluid group 1</p> <p>Liquids: Fluid group 1;</p> <p>meets requirements as per Section 3, Subsection 3 (sound engineering practice)</p>

Selection and Ordering data	Article No.
SITRANS P280 WirelessHART pressure transmitter	▶ 7MP1120-
(Required battery not included with delivery, see accessories)	0
Measuring cell filling	0
Dry measuring cell	
Measuring span	
Gauge pressure	
0 ... 1.6 bar (0 ... 23 psi)	D
0 ... 10 bar (0 ... 145 psi)	E
0 ... 50 bar (0 ... 725 psi)	F
0 ... 200 bar (0 ... 2900 psi)	G
0 ... 320 bar (0 ... 4641 psi)	H
Absolute pressure	
0 ... 1.6 bar a (0 ... 3 psia)	M
0 ... 10 bar a (0 ... 145 psia)	N
0 ... 50 bar a (0 ... 725 psia)	P
0 ... 200 bar a (0 ... 2900 psia)	Q
0 ... 320 bar a (0 ... 4641 psia)	R
Wetted parts	
Ceramic	K
Display	
Display, visible	1
Enclosure	
Die-cast aluminum	1
Process connection	
G½ as per EN 837-1	0
½-14 NPT	1
Explosion protection	
Without	A
Antenna	
Variable, attached to device	A
Further designs	Order code
Please add "-Z" to Article No. and specify Order code(s) and plain text.	
Stainless steel tag plate (measuring point description)	Y15
max. 16 digits entered in plain text	
Y15:	
Measuring point message	Y16
max. 27 characters entered in plain text: Y16:	
Accessories	Article No.
Lithium battery for SITRANS TF280/P280	▶ 7MP1990-0AA00
Mounting bracket, steel	7MF4997-1AC
Mounting bracket, stainless steel	▶ 7MF4997-1AJ
Cover, die-cast aluminum, without window	7MF4997-1BB
Cover, die-cast aluminum, with window	▶ 7MF4997-1BE
IE/WSN-PA LINK	see Sec. 7
HART modem with RS232 interface	▶ 7MF4997-1DA
HART modem with USB interface	▶ 7MF4997-1DB
SIMATIC PDM	see Sec. 8
▶ Available ex stock	

Pressure Measurement

Transmitters with WirelessHART

SITRANS P280
for gauge and absolute pressure

1

Dimensional drawings

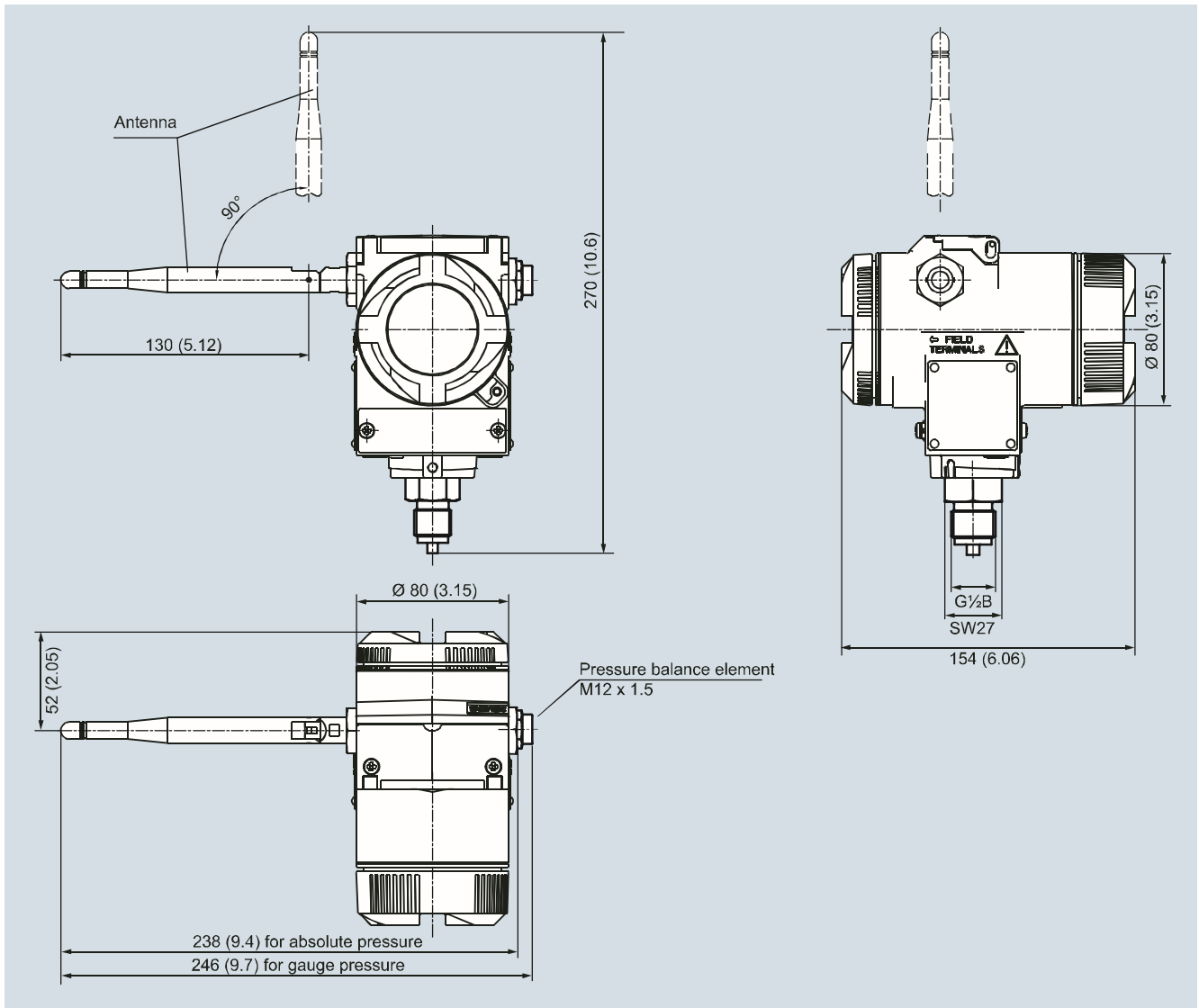

SITRANS P280 WirelessHART pressure transmitter, process connection G 1/2", dimensions in mm (inch)
The dimensional drawing of the mounting bracket see on page 1/166.

Pressure Measurement Transmitters with WirelessHART

SITRANS P280
for gauge and absolute pressure

1

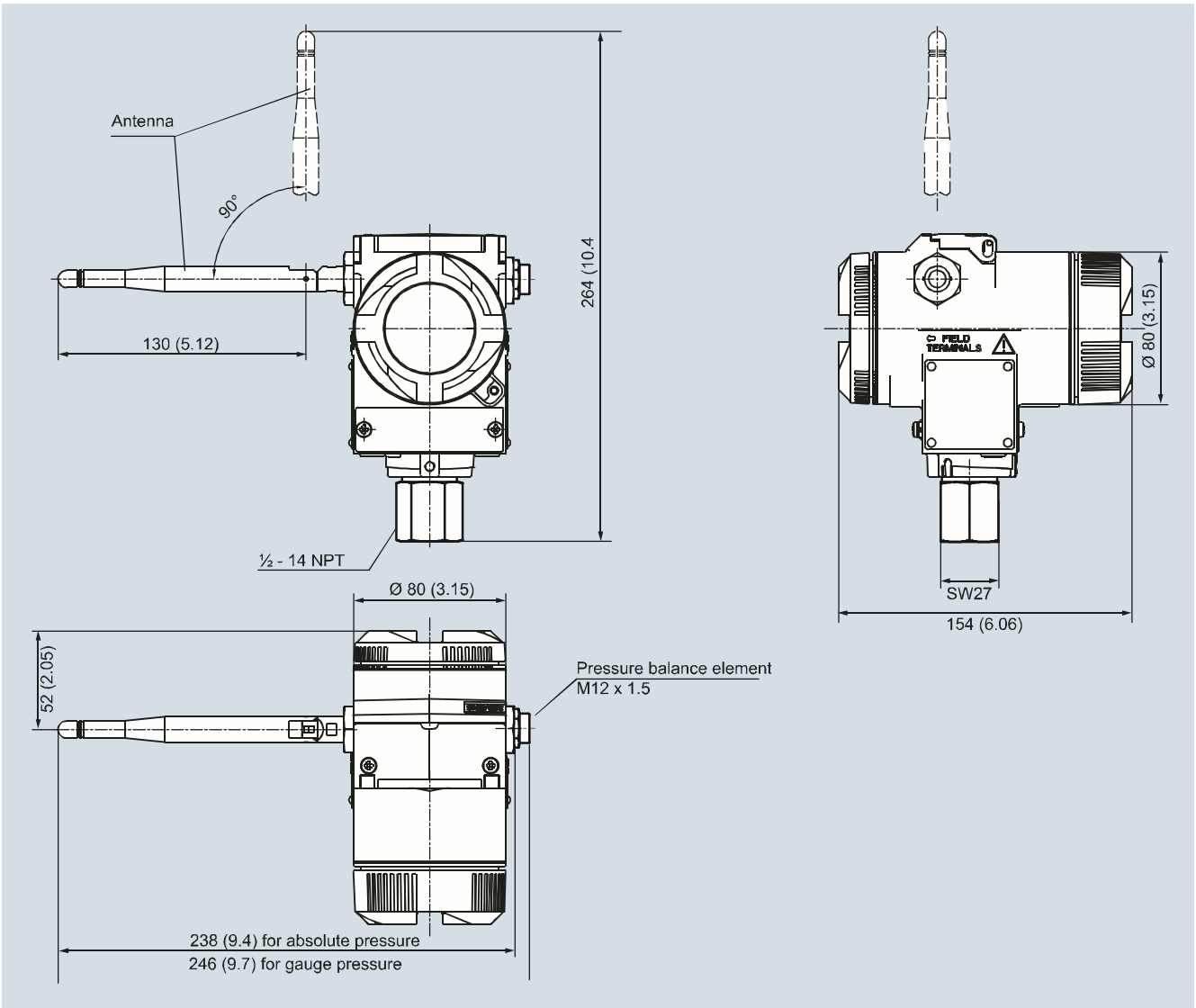

SITRANS P280 WirelessHART pressure transmitter, process connection 1/2 - 14 NPT, dimensions in mm (inch)
The dimensional drawing of the mounting bracket see on page 1/166.